

## Product Information

Serial No.	Model No.	Description	Pool Volume	Flowrate
88390201	EMD-11C	S500 Sand Filter, SS050 Pump, CL-01A Chlorine Feeder and PSB016 Submersible Pump	66m <sup>3</sup>	11m <sup>3</sup> /h
88390202	EMD-11CP	S500 Sand Filter, SS050 Pump, CL-01A Chlorine Feeder, SR30 Booster Pump and PSB016 Submersible Pump	66m <sup>3</sup>	11m <sup>3</sup> /h
88390301	EMD-14C	S650 Sand Filter, SS100 Pump, CL-01A Chlorine Feeder and PSB016 Submersible Pump	84m <sup>3</sup>	14m <sup>3</sup> /h
88390302	EMD-14CP	S650 Sand Filter, SS100 Pump, CL-01A Chlorine Feeder, SR30 Booster Pump and PSB016 Submersible Pump	84m <sup>3</sup>	14m <sup>3</sup> /h
88390401	EMD-18C	S700 Sand Filter, SC150 Pump, CL-01A Chlorine Feeder and PSB016 Submersible Pump	108m <sup>3</sup>	18m <sup>3</sup> /h
88390402	EMD-18CP	S700 Sand Filter, SC150 Pump, CL-01A Chlorine Feeder, SR30 Booster Pump and PSB016 Submersible Pump	108m <sup>3</sup>	18m <sup>3</sup> /h
88390601	EMD-25C	S800 Sand Filter, SB20 Pump, CL-01A Chlorine Feeder and PSB016 Submersible Pump	150m <sup>3</sup>	25m <sup>3</sup> /h
88390602	EMD-25CP	S800 Sand Filter, SB20 Pump, CL-01A Chlorine Feeder, SR30 Booster Pump and PSB016 Submersible Pump	150m <sup>3</sup>	25m <sup>3</sup> /h
88390701	EMD-32C	S900 Sand Filter, SB30 Pump, CL-01A Chlorine Feeder and PSB016 Submersible Pump	192m <sup>3</sup>	32m <sup>3</sup> /h
88390702	EMD-32CP	S900 Sand Filter, SB30 Pump, CL-01A Chlorine Feeder, SR30 Booster Pump and PSB016 Submersible Pump	192m <sup>3</sup>	32m <sup>3</sup> /h



# EMD Series In-ground Filter System

SIMPLE OPERATION WITH CONTROL BOX  
**Easy installation with pre-installed plumbing and durable, weatherproof enclosure**



**e Emaux**  
 water technology

**Pool & Spa Equipment**

**EMAUX WATER TECHNOLOGY CO., LTD**

ADDRESS: Flat A-D, 20/F., Kai Bo 22, 22 Wing Kin Road,  
 Kwai Chung, Hong Kong  
 PHONE +852 2832 9880  
 www.emaugroup.com

**Pool & Spa Equipment**

**YOUR PREMIER SUPPLIER**

Available from:

ALL SPECIFICATIONS ARE SUBJECT TO CHANGE WITHOUT NOTICE  
 © 2021 EMAUX WATER TECHNOLOGY CO., LTD. ALL RIGHTS RESERVED.

www.emaugroup.com

# Filtration System **EMD SERIES**

## ADVANTAGES OF EMD SYSTEM

### The Enclosure

1. Made from durable, corrosion resistant fiberglass reinforced plastic. Withstands UV and low temperature
2. Watertight and equipped with a submersible pump to drain water automatically
3. The filter systems are suitable for all kinds of pool shapes and sizes, and can be customized to your specific requirements.
4. Simple installation can be completed in just a few hours

### Timer-controlled Automation

1. Eliminates the needs for manual power on/off and professional staff for maintenance
2. Convenient and user-friendly

### The Content

1. The system consists of a subsystem for filtration, hydraulic massage, sanitizing and lighting
2. Service Lights installed on the corner will turn on automatically when the cover is open
3. It can be equipped with salt water chlorinator which is the most effective and widely used means for sanitization

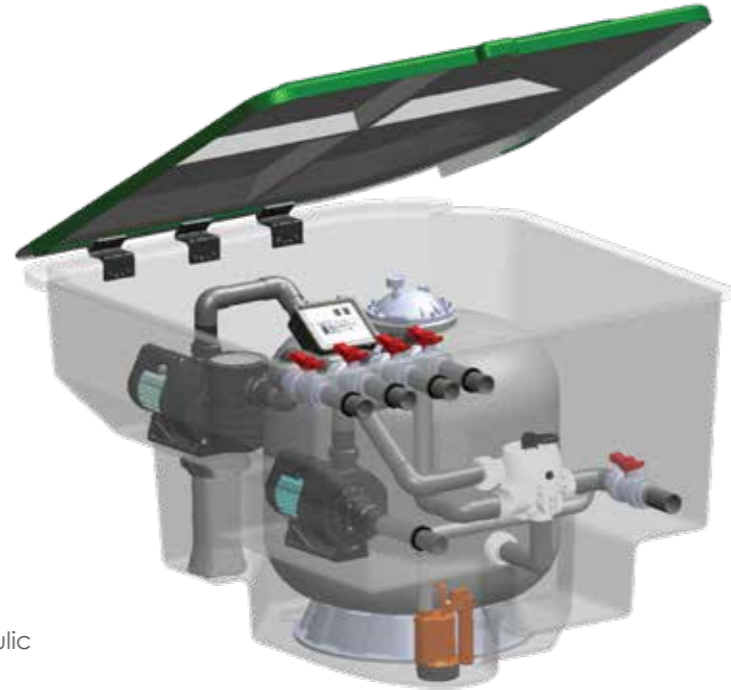

### Product Features

Max Working Pressure

**36psi/2.5bar**

Max Water Temperature

**43°C (109°F)**

Suggested Size Of Media

**0.5-0.8mm**

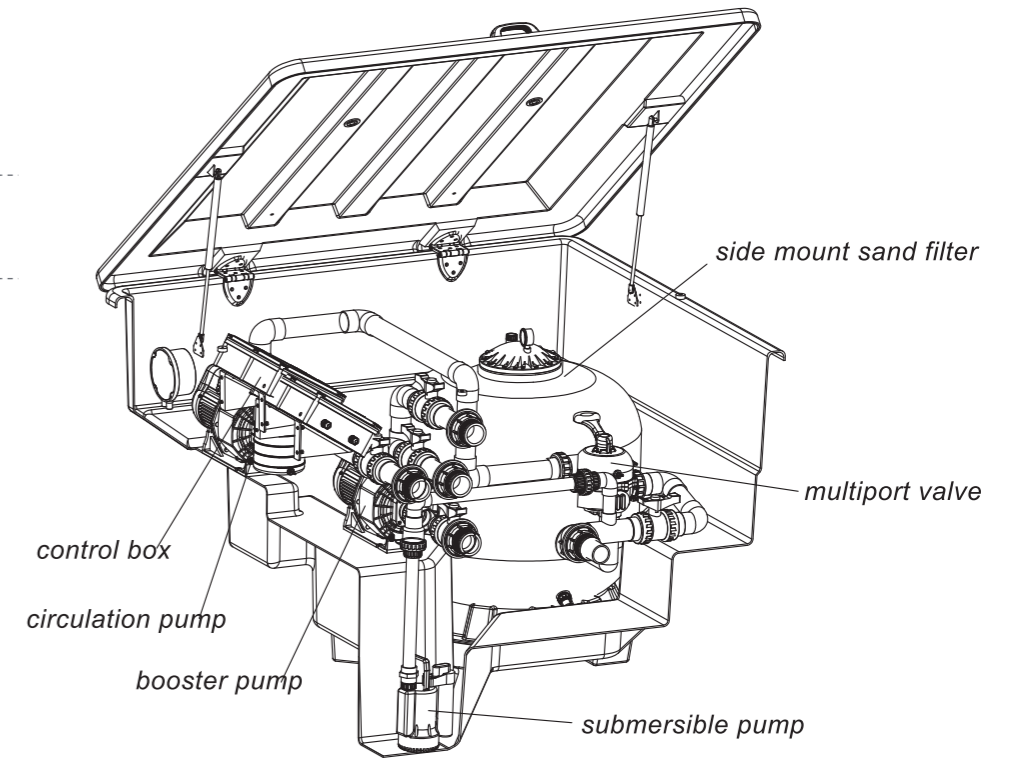

### Product Dimensions

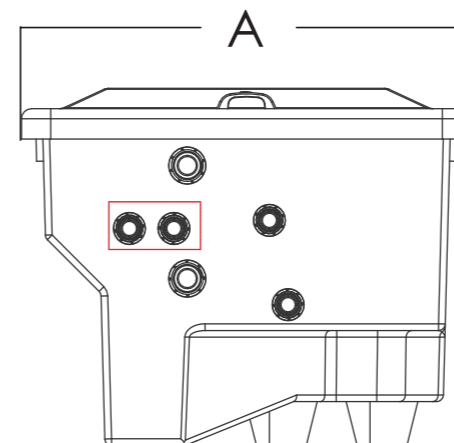
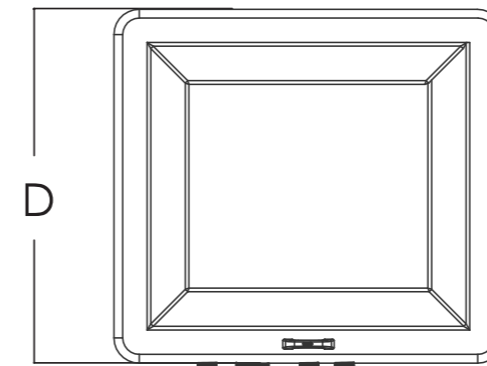

Model	A mm	B mm	C mm	D mm
EMD-11	1330	1055	905	1210
EMD-14	1330	1055	905	1210
EMD-18	1400	1220	1080	1340
EMD-25	1730	1315	1170	1630
EMD-32	1730	1315	1170	1630

