

## 5 0 Spare Parts

### 5 1 Ozone Generator Parts

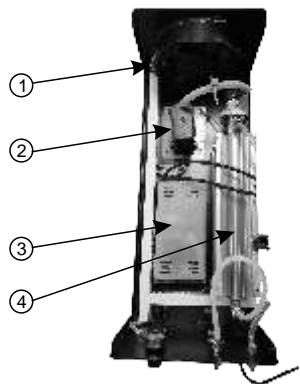

ITEM NO.	PART DESCRIPTION	BIN REF.
1	FAN	01
2	IGNITOR	02
3	REACTION DEVICE	03
4	INTEGRATED CIRCUIT	04

### 5 2 Air Dryer Parts

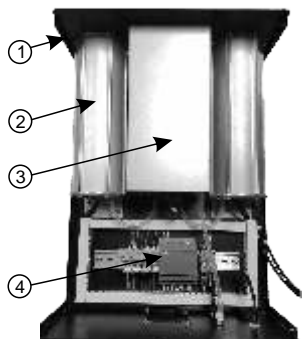

ITEM NO.	PART DESCRIPTION	BIN REF.
1	FAN	01
2	CANISTER OF DRYING	02
3	ELECTROMAGNETIC VALVE	03
4	REACTION DEVICE	04



# OZO PLUS SYSTEM DISINFECTION

## Installation & Operating Instructions



EMAUX (ZhongShan)Swimming Pool Equipment Co., Ltd  
 Tel: +0760 85527988  
 Fax: +0760 85527188  
 Jan 2018

# Contents

1.0 Introduction	3
1.1 General & Technical Information	3
1.2 Electrical Information	3
2.0 Description Of Equipment	4
2.1 Ozone Generator	4
2.2 Air Dryer	4
2.3 Vacuum Induction System	5
2.4 Contact / Degassing System	5
3.0 Installation Of Equipment	5
3.1 Water Trap Assembly	5
3.2 Ozone Generator	6
3.3 Air Dryer	6
3.4 Ozone Generator Mounting Detail	7
3.5 Dryer Mounting Detail	7
3.6 ZOG-4G Installation Diagram	8
3.7 ZOG-8G Installation Diagram	8
3.8 Water Trap Diagram	9
3.9 Electrical Installation	10
3.10 Manual Control	10
3.11 Time Clock Control	10
4.0 Operation Of Equipment	10
4.1 Starting The Ozone System	10
4.2 Operation & Maintenance	11
5.0 Spare Parts	12
5.1 Ozone Generator Parts	12
5.2 Air Dryer Parts	12

- 3 Disconnect the flexible tubing between the water trap assembly and the ozone generator .
- 4 With the main circulation system running ,open both system isolating valves to the flood system ,check the system for any signs of water leakage and also that the check valve assembly within the water trap unit has stopped any backflow of water from the injector .
- 5 Start the booster pump to ensure that suction is achieved at the side connection of the water trap assembly .The booster pump should be stopped and re started several times to ensure that the ball check valve incorporated in the water trap assembly seals properly and stops any water backflow from the injector .Once this has been checked ,then the suction connection to the ozone generator can be remade .
- 6 Switch on the ozone generator (and air dryer )and then re start the booster pump .Air should now be drawn through the ozone system .
- 7 Check the airflow through the ozone generator and set to 12 litres /min .utilising the booster pump discharge valve to control the air flow through the ozone generator .
- 8 If the system is fitted with the degasser system ,check that the automatic air release valve is venting the column properly and maintaining a near static water level within the column .
- 9 Check that there is no smell of ozone from the area of the activated carbon filter pot .If there is ,turn off the ozone generator ,air dryer if fitted ,and booster pump and carry out the checks in 1 and 2 .
- 10 Check that the system operates correctly under time clock or redox control if fitted and that if the main circulating pump stops ,the ozone system stops .
- 11 Check that the booster pump always maintains a flooded suction after the main circulating pump has been switched off .

## 4 2 Operation & Maintenance

The ozone system has been designed for either periodic or continuous running with the minimum of maintenance and supervision but the following checks should be carried out at a minimum of once per week .

Check that ozone generator and air dryer indicator lights are illuminated when the system should be in operation .

Check the level of water in the water trap pot and top up as required to the correct level of 25mm from the top of the pot .

Check that the correct airflow is being drawn through the ozone generator and adjust if necessary .

Check that the injector booster pump is operating correctly .

On systems fitted with the optional degasser system , it is necessary to check the activated carbon in the activated carbon filter pot which will degenerate through usage . When the carbon level falls to approximately 25mm from the top of the container the system must be topped up .

*Note :It is the responsibility of the user to ensure that the correct level of activated carbon is maintained . Spare activated carbon can be purchased in 2kg packs from Triogen or your local distributor . Maximum output of the generator is attained when the control knob is set to position 10 . The airflow through the generator should be maintained at the recommended 10 -12 litres /minute , irrespective of the setting used for the variable output .*

It should be noted that the noise emitted by the generator may fluctuate as the output is varied but this will stabilise within a few minutes as the temperature of the inner electrode increases or decreases in accordance with the amount of power supplied to the ozone module .

## 3 9 Electrical Installation

The electrical installation of the equipment should only be carried out by trained personnel .

The ozone generator and dryer should be fitted with mains plugs in accordance with the electrical safety instructions .

The mains socket into which the units are to be connected should be of the wall mounted SWITCHED mains outlet type .The socket must be earthed .

The mains outlet socket can take its electrical feed from various sources ,depending on the method of control .

The injector booster pump should be electrically installed in line with manufacturers recommendations and should be interlocked with the main circulation pump .

OZG 4G ozone system requires a double outlet switched wall socket .

OZG 8G ozone system requires a triple outlet switched wall socket .

The number of outlets above do not accommodate the injector booster pump supply as this would normally be incorporated in the main filtration control panel or from a separate pump starter unit .

NOTE :1 .UNDER NO CIRCUMSTANCES SHOULD THE GENERATOR OR THE AIR DRYER BE HARD WIRED DIRECTLY TO A POWER SUPPLY .IF THIS IS DONE ,THE WARRANTY OF THE UNITS ARE IMMEDIATELY INVALID .

2. UNDER NO CIRCUMSTANCES SHOULD THE GENERATOR OR THE AIR DRYER BE WIRED DIRECTLY INTO A FILTRATION CONTROL PANEL OR SIMILAR – THEY MUST BE WIRED AS INSTRUCTED ABOVE.

The reason for the above is to ensure that the units can be easily removed either for winter storage or servicing .

## 3 10 Manual Control

If the ozone generator is to be manually controlled ,the feed to the mains socket should be directly from the main filtration control panel and interlocked with the main circulating pump starter to ensure that the ozone system stops if the main circulation system stops .The switch on the mains outlet socket can then be used to stop and start the ozone system manually as long as the circulating system is operational .

## 3 11 Time Clock Control

If the ozone system is to operate under time clock control together with other items of equipment ,then the ozone system and booster pump should be fed from the master control panel controlling all other equipment ,again via a switched wall socket into which the ozone generator and air dryer are plugged .

IN ALL CASES ,THE OZONISER MUST BE PLUGGED INTO A SWITCHED OUTLET SOCKET WHICH IS FED FROM ANY OF THE ABOVE SOURCES AND INCORPORATES PROPER EARTHING CONNECTIONS .

## 4 0 Operation Of Equipment

### 4 1 Starting The Ozone System

The start up of the ozone system will depend largely on how the system has been installed but the following checks should be carried out :

1 Check that the water trap pot and the degasser drain pot ,if fitted ,have been filled with water to a level of 25mm from the top of the pots and that all interconnecting tubing is correctly installed .

2 If the system is fitted with the optional degasser system ,check that the activated carbon filter pot has been charged with gravel and activated carbon .

## 1 0 Introduction

### 1 1 GENERAL INFORMATION & TECHNICAL INFORMATION

#### ZOG-4G OZO SYSTEM COMPRISES

1 - OZONE GENERATOR

1 - AIR DRYER

1 – INJECTOR

1- MIXER

1 - WATER TRAP ASSEMBLY

1 - 8mm PTFE TUBING 3 METRES

#### ZOG-8G OZO SYSTEM COMPRISES

1 - OZONE GENERATOR

1 - AIR DRYER

1– INJECTOR

1- MIXER

1 - 8mm PTFE TUBING 3 METRES

2 - 8mm TEE-PIECE

#### SYSTEM COMPRISES

1 - CONTACT TANK

1 - AUTOMATIC VENT VALVE

1 - CARBON DESTRUCT FILTER

1- OZONE SYSTEM ASSEMBLY



#### TECHNICAL INFORMATION OF OZONE GENERATOR

OZONE OUTPUT (gm/hr) :2 .0

VOLTAGE (v/ph/hz) :220 -240 /1 /50 -60

POWER (watts) :100

DIMENSIONS (mm) :543H x 235W x 283D

WEIGHT (kg) :9 .0



#### TECHNICAL INFORMATION OF AIR DRYER

AIR OUTPUT (ltr/min) :24

VOLTAGE (v/ph/hz) :220-240/1 /50-60

POWER (watts) :60

DIMENSIONS (mm) :543H x 375W x 283D

WEIGHT (kg) :16.3

### 1 2 Electrical Information

Symbols : The lightning flash with arrowhead symbol is to alert the user to the presence of uninsulated “dangerous voltage” within the product enclosure that may be of sufficient magnitude to constitute risk of electric shock to persons The warning label is to instruct service personnel to disconnect the mains supply before removing the front cover .

Caution :To reduce the risk of fire or electric shock ,do not expose this unit to excessive temperatures ,rain or moisture .Always disconnect this unit from the supply when not in use for lengthy periods .

Important :Servicing should only be done by qualified personnel .No user- serviceable parts inside .

## MAINS OPERATION

The wires in the lead are coloured in accordance with the following wiring codes:

BROWN -----LIVE  
BLUE -----NEUTRAL  
YELLOW/GREEN -----EARTH

The wires in the mains lead must be connected to the terminals

BROWN WIRE -----L OR RED  
BLUE WIRE -----N OR BLACK  
YELLOW/GREEN -----E OR EARTH

NOTE: THIS UNIT MUST BE EARTHED.

## INTERNAL FUSES

The following fuses are fitted within the equipment :

OZONE GENERATOR

220 240V 5A

AIR DRYER

220 240V 5A

## 2 0 Description Of Equipment

### 2 1 Ozone Generator

Emaux ozone generators comprise three main components—a high voltage High frequency power board driving a ceramic corona discharge module which is air Cooled by an integral cooling fan .Normal atmospheric air can be used as the feed gas or pre dried air supplied by a Emaux air dryer, either of which is drawn through the ozone generator under Vacuum which is created by a water driven venture injector .When the unit is switched on , an electrical corona discharge is formed within the module by the power being supplied From the board . This reforms the oxygen molecules (O<sub>2</sub>) present in the feed gas into Ozone (O<sub>3</sub>) as the air passes through the module .

As heat is produced by the generation of the corona discharge ,it is necessary to cool The module during operation .This is achieved by the use of an integral cooling fan fitted within the ozone generator The high voltage high frequency power board in corporate full overload and short circuit protection Inaddition a thermostat is fitted to the module which will isolate the power in the event of a cooling fan failure causing the module to overheat The ozone generator is fitted with an output control knob located on the underside of the Unit adjacent to the pipe connectors ,which electrically varies the ozone output between 0 and 100% of the rated output of the unit .

### 2 2 Air Dryer

Emaux air dryers are fully automatic desiccant dryers which are electronically Controlled for reliability and ease of use The dryer contains two desiccant columns with integral heater elements two three port Solenoid valves an air pump for purging moisture from the columns all of which are Controlled by aprogrammable relay When one column is drying the air the other column automatically heats up and the small purge pump passes air in reverse flow through the column to drive out the moisture retained within the desiccant material .After a pre set period of time ,the heater and pump are switched off to allow time for the column to cool down prior to it going on stream to allow regeneration of the other column This process is continuous unless the unitis switched off Automatic cycling of the air dryer columns is controlled by a no - maintenance programmable relay ensuring no loss of cycling sequence when the unitis switched off .

## 3 8 Water Trap Diagram

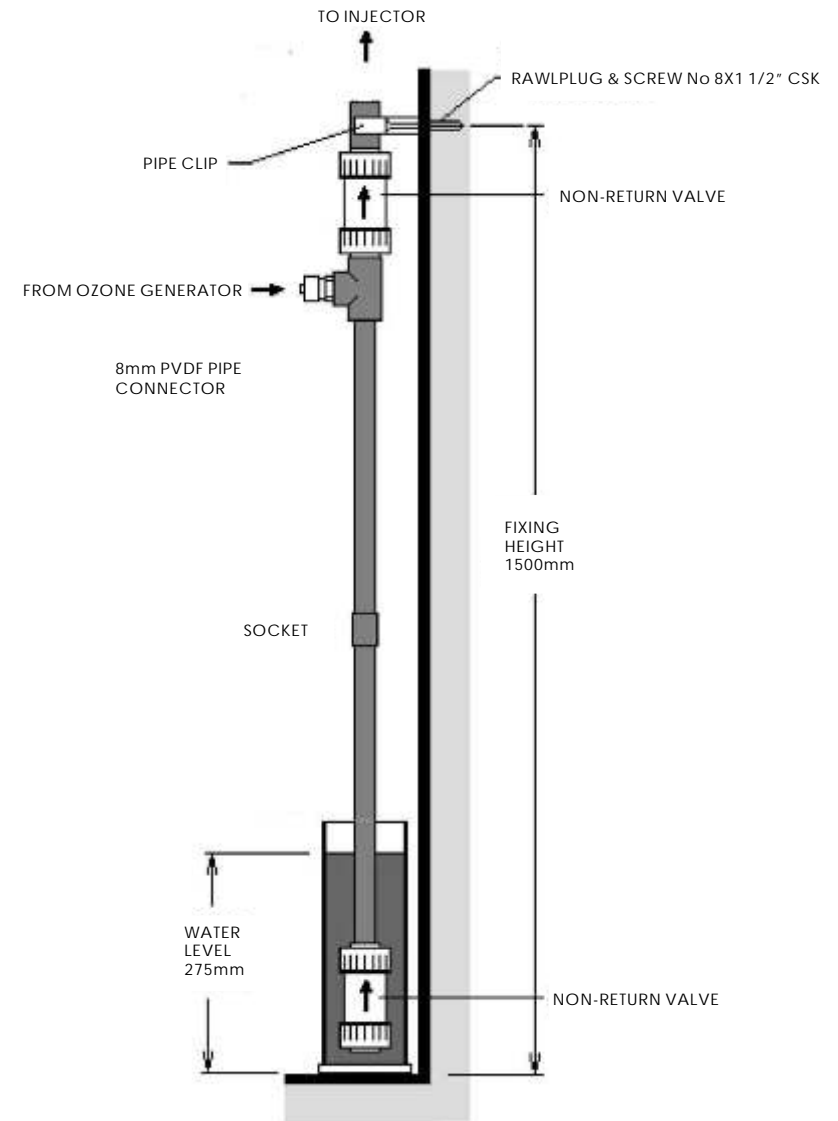

### 3 6 ZOG-4G Installation Diagram

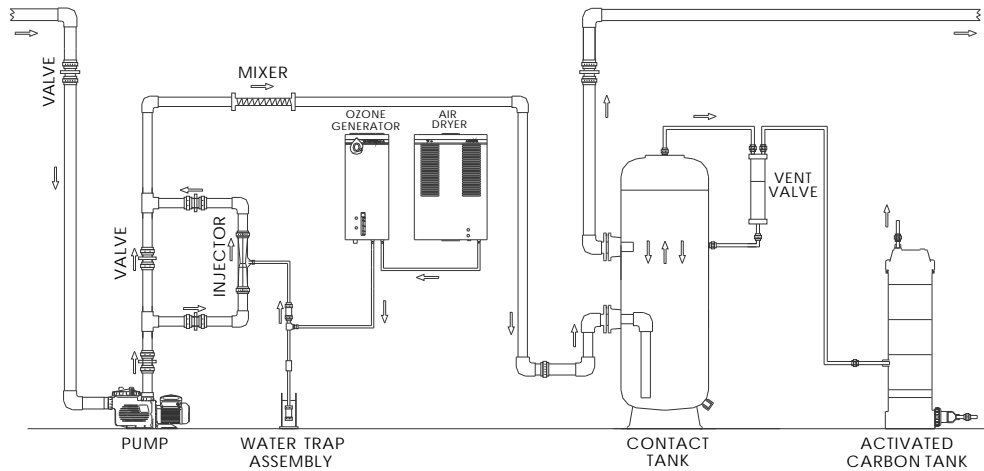

### 3 7 ZOG-8G Installation Diagram

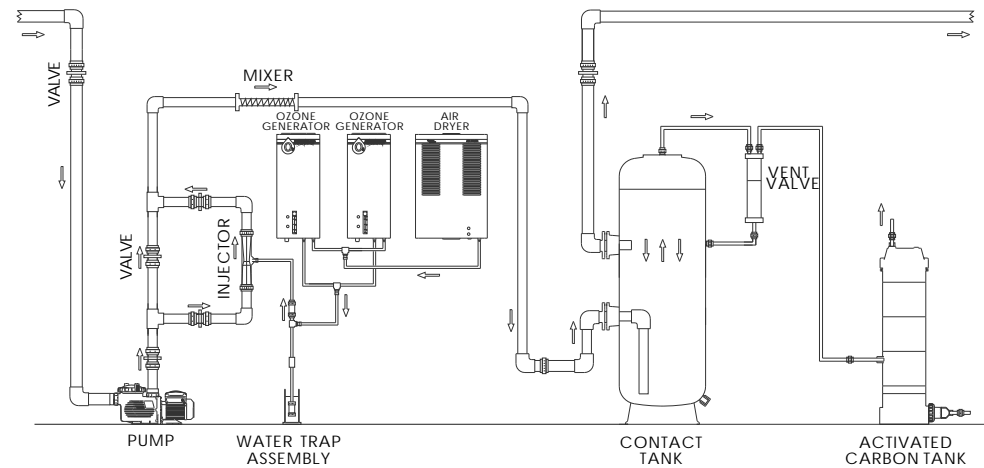

### 2 3 Vacuum Induction System

The ozone induction system is comprised of an air to water venture injector which is driven by a water booster pump .

The booster pump takes its supply from the filtered water return pipe to the pool and increases the pressure of the water that then passes through the venturi injector .The Design of the injector then uses this pressure to induce a vacuum at the side connection Of the unit which is connected to the ozone generator via a water trap assembly .

It is the creation of this vacuum that draws the air through the ozone generator and then into the injector where the ozone gas then mixes with the water stream The amount of suction created by the injector can be controlled by varying the water flow From the booster pump by adjusting the valve fitted in the pump discharge line .Alteration of the air flow through the generator also controls the amount of ozone gas produced .

### 2 4 Contact / Degassing System

An optional contact degassing system is available which virtually eliminates the air bubbles present in the ozonised water stream thereby avoiding air entering the pool through the water inlet system .

The system comprises of a contact tank fitted with an external combined level control and venting valve which vents the excess air and any ozone gas present to an ozone gas destruct unit which destroys any ozone gas before venting to the atmosphere The ozone gas destruct unit consists of a wall mounted container which is filled with activated carbon through which the vented air from the degasser unit is passed . Any excess ozone gas present reacts with the carbon and is converted back to oxygen before being released to the atmosphere .

It is strongly recommended that a degassing system is adopted as entrained air entering The pool can be visually unacceptable and could have a bleaching effect on pool liners or covers .

## 3 0 Installation Of Equipment

The installation of the equipment should only be carried out by engineers who are trained in fitting standard pool filtration equipment .

### 3 1 Water Trap Assembly

A water trap assembly ,as shown in the typical installation diagrams ,must always be used to ensure that water cannot pass from the injector to the ozone generator when the water booster pump is stopped .The water trap assembly should be wall mounted as close as possible to the injector at a distance not exceeding 3 metres and at the height indicated .

After mounting ,the injector suction should be connected to the top connection of the water trap assembly utilising the flexible tubing supplied .The tubing should be clipped to the wall at 300mm centres to prevent the tubing from kinking under it's own weight, particularly at the top connection to the water trap.

### 3 2 Ozone Generator

The ozone generator should be wall mounted as close as possible to the water trap assembly at a distance not exceeding 3 metres and a minimum height of 1.65 metres above floor level. The ozone generator MUST only be wall mounted utilising the two screw fixings included with the unit.

When the position of the ozone generator has been ascertained, the two hole centres should be marked and drilled in accordance with the fixing centres of the unit. Insert the plastic rawlplugs into the drilled holes and then insert the roundhead screws until the screw head is protruding 3mm above the surface. The ozone generator is then hung on the screw fixings utilising the keyhole slots on the rear of the unit.

After mounting, the ozone generator air outlet should be connected to the side connection of the water trap assembly utilising the 8mm flexible PTFE tubing supplied with the unit and supported at 300mm centres to prevent the tubing from kinking under its own weight, particularly at the side connection to the water trap. The air flowmeter included with the ozone generator should be connected to the air inlet of the ozoniser utilising a 25mm long piece of the 8mm flexible PTFE tubing supplied.

When selecting a location for the ozoniser, the following instructions should be adhered to:

The ozone generator should not be located in a position that subjects the equipment to rain or moisture.

The ozone generator should not be located in the vicinity of any chemical storage tanks that are likely to emit chemical fumes.

The ozone generator should not be located in the vicinity of any other equipment that emits heat. The unit operates with fan assisted cooling and therefore any obstruction of ventilation or excessive heat will cause damage and shorten the life of the equipment.

If the ozone generator is being installed in an unheated outdoor plantroom for use with a seasonal outdoor pool, then the unit should be removed at the end of the season and stored indoors until required.

The ozone generator produces high voltage electricity, therefore never remove the outer cover while the unit is connected to the mains power supply.

### 3 3 Air Dryer

The air dryer should be wall mounted adjacent to the ozone generator at the same height, leaving an air gap of 50mm between the units. The units should only be mounted side by side and never above or below each other. The air dryer MUST only be wall mounted utilising the two screw fixings included with the unit.

When the position of the air dryer has been ascertained, the two hole centres should be marked and drilled in accordance with the fixing centres on the unit. Insert the plastic rawlplugs into the drilled holes and then insert the roundhead screws until the screw head is protruding 3mm above the surface. The air dryer is then hung on the screw fixings utilising the keyhole slots on the rear of the unit.

Under no circumstances should the air dryer cover be removed and the unit screwed tightly to the wall as the wall fixing method described above is to allow easy removal of the unit should it be required.

It should be noted that the air dryer utilises heat to regenerate the desiccant material and therefore contact with the outer casing should be avoided when the unit is in operation. It should also be noted that the unit emits steam during its regeneration cycle and therefore it should be located away from any other equipment which may be affected by condensation.

### 3 4 Ozone Generator Mounting Detail

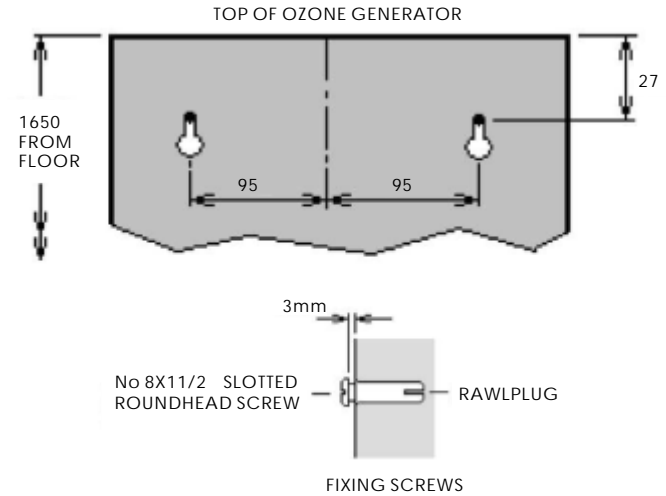

### 3 5 Dryer Mounting Detail

