

EMAUX IN-GROUND FILTRATION COMBO

THE CLEAR CHOICE IN WATER TECHNOLOGY

- Suggested Installation: Domestic swimming pool.
- Easy installation with pre-installed plumbing system with durable enclosure.
- Simple operation with control box.
- UV resistance for the top cover.
- Max operating pressure 36psi / 2.5 bar.
- Max temperature of 43°C (109 °F).
- Suggested size of quartz sand : 0.5-0.8mm.

- To produce and introduce new technology from Australia and the enclosure is made from glass fibre enhanced plastic is durable and resistive to corrosion, rust, low temperature and UV.
- Suitable for pools of different shapes and sizes. Selection of system components can be customized to your specific requirements.
- Timer-controlled automation eliminates the need(s) for manual power-on/off and professional staff for maintenance; when backwash is called for you just need to turn the 6-position multiport valve to clean up the sand filter, which makes it more convenient and environmental friendly than other filtration devices using filter pockets.
- The enclosure is water-tight and can drain water automatically.
- Eliminate the need(s) for building equipment rooms and installation, which saves much labour and time.
- Simple installation can be completed within hours.
- The system consists of a subsystem for filtration, hydraulic massage, sanitizing and lighting.
- Lights will turn on automatically when the cover is open, which makes it suitable for operation at dim condition.
- Equipped with salt water chlorinator, the most effective and widely used means for sanitization.

TABLE OF CONTENT

Installation of In-ground filtration Combo	3-7
Control Box Operation	8-14
Filter Operation	15-22
Pump Operation	23-29
Salt Chlorinator Operation	30-35

Installation of In-ground filtration Combo (1)

Product Series: EMD-7C / EMD-7CP / EMD-7S / EMD-7SP / EMD-7SL / EMD-7SPL / EMD-11C / EMD-11CP / EMD-11S / EMD-11SP / EMD-11SL / EMD-11SPL / EMD-14C / EMD-14CP / EMD-14S / EMD-14SP / EMD-14SL / EMD-14SPL / EMD-18C / EMD-18CP / EMD-18S / EMD-18SP / EMD-18SL / EMD-18SPL / EMD-22CEMD-22CP / EMD-22S / EMD-22SP / EMD-22SL / EMD-22SPL / EMD-25C / EMD-25CP / EMD-25S / EMD-25SP / EMD-25SL / EMD-25SPL / EMD-32C / EMD-32CP / EMD-32S / EMD-32SP / EMD-32SL / EMD-32SPL

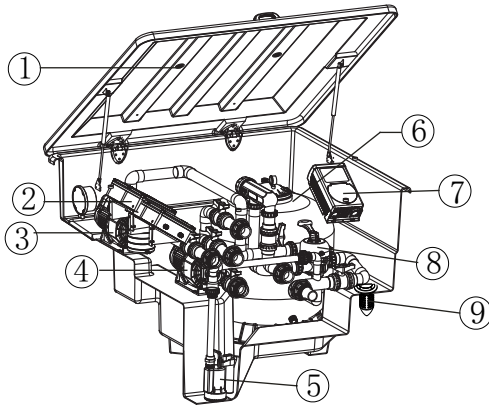
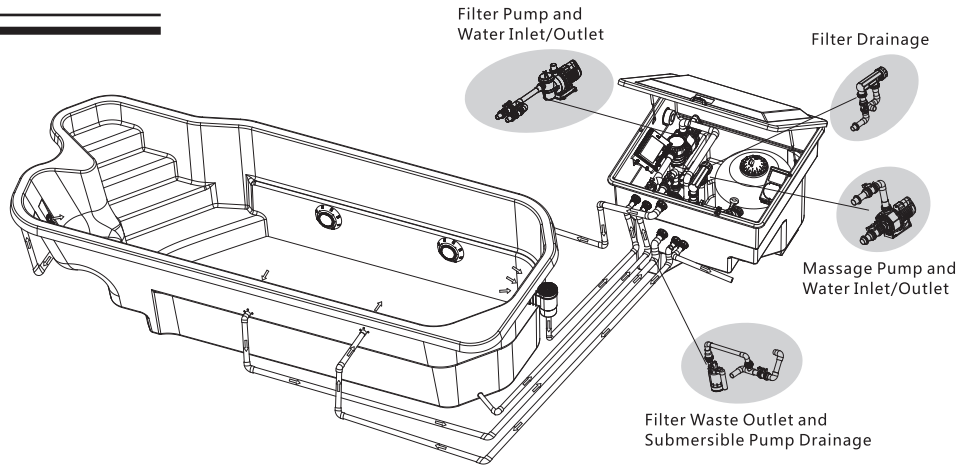

Code	Description
1	Illminating Lamp
2	Control Box
3	Circulation Pump
4	Booster Pump
5	Submersible Pump
6	Side Mount Sand Filter
7	Salt Chlorinator
8	Multiport Valve
9	Hydrostatic Valve

Installation of In-ground filtration Combo (2)

A) SAFETY

ATTENTION: Read the instruction carefully

In order to ensure your safety, that of other people and the optimum functioning of the equipment, the installation of this product should be carried out by a qualified electrician/ pumper. Read through this manual before installation. Carry out the installation in accordance to the local safety regulation for the swimming pools equipment and electrical appliances. Failure to do so may result in injury, death or property damage. This manual should keep this manual for future use.

Although the cover is design to carry the weight of an adult, it doesn't allow children or adults to walk or jump on the cover, nor carry out activities which pose risk of equipment damage.

ATTENTION: Cleaning

Always clean with a dampened cloth and neutral soap solution. Do not use detergent containing solvents or acids.

ATTENTION

Use for swimming pools and spas only

ATTENTION: Period of non-use

It is recommend that the electricity is cut off for non-use

B) INSTALLATION

For safety concern, it is suggested to install the in-ground filtration combo at a distance of no less than 3.5m from the edge of the swimming pool. And do not adjust the equipment setting when the pool is being used.

- 1) Carefully mark for the layout of the filtration combo
- 2) Carry out the escalation according to the measurement indicated. Flatten the bottom and create a gravel base.
- 3) Set the filtration combo in place
- 4) Prepare the ground for the installation of the pipes
- 5) Connect the pipes and the electrical wire a illustrated below
- 6) Backfilling the hole around the filtration combo with sand and cement. **MANWORK ONLY, BULLDOZER PROHIBITED.**

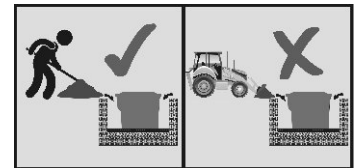

Installation of In-ground filtration Combo (3)

VALVE SETTING

OPERATION	VALVE POSITION	CHECK VALVE POSITION
1 FITERN FILTER FILTRATION FILTRACION		
2 RÜCKSPÜLEN BACKWASH LAVAGE LAVADO		
3 NACHSPÜLEN RINSE ENJUAGUE		

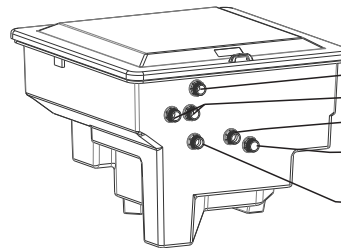
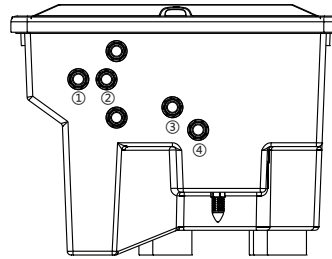

- Massage Pump Outlet
- Filter Pump Inlet
- Filter Drainage
- Filter waste outlet and submersible Pump drainage
- Massage Pump Inlet

OPERATION	VALVE POSITION	CHECK VALVE POSITION
4 ENTLEREN WASTE EGOUT DESAGÜE		
5 ZIRKULIEREN RECIRCULATE CIRCULATION CIRCULACION		
6 GESCHLOSSEN CLOSED FERME CERRADO		

Installation of In-ground filtration Combo (4)

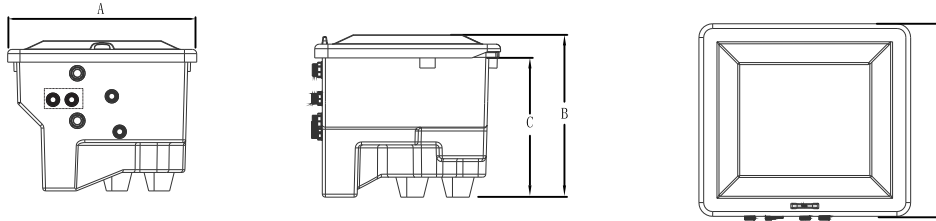

Model No.	A(mm)	B(mm)	C(mm)	D(mm)	C/S/SL		CP/SP/SPL	
					ØN1	ØN2	ØN1	ØN2
EMD-7	1330	1055	905	1210	DN50	/	DN50	DN63
EMD-11	1330	1055	905	1210	DN50	/	DN50	DN63
EMD-14	1330	1055	905	1210	DN50	/	DN50	DN63
EMD-18	1400	1220	1080	1340	DN50	/	DN50	DN63
EMD-22	1400	1220	1080	1340	DN50	/	DN50	DN63
EMD-25	1730	1315	1170	1630	DN63	/	DN63	DN63
EMD-32	1730	1315	1170	1630	DN63	/	DN63	DN63

C) MAINTENANCE

Open the cover of the in-ground filtration combo, the cover is support by 2 hydraulic hinges.

ATTENTION

Ensure the equipments inside is turned off before adjusting any valves.

Installation of In-ground filtration Combo (5)

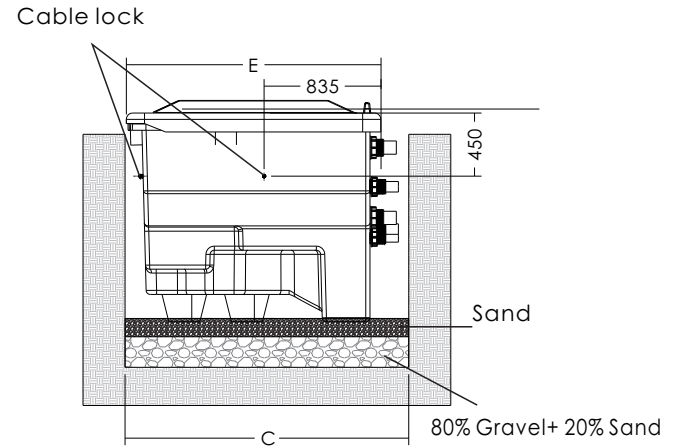
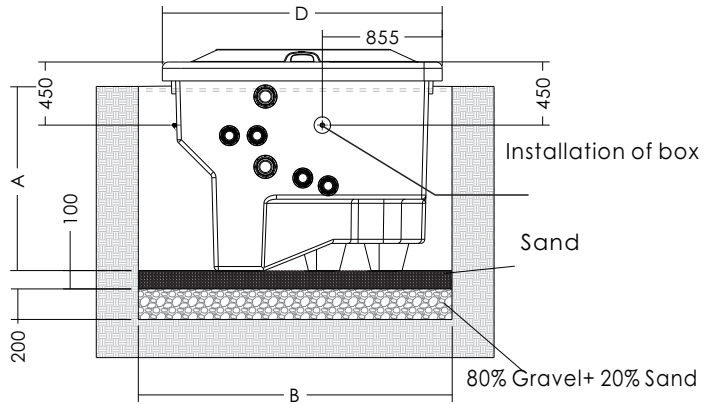

Model No	A(mm)	B(mm)	C(mm)	D(mm)	E(mm)
EMD-7	850	1800	1650	1330	1210
EMD-11					
EMD-14					
EMD-18	1020	1800	1750	1400	1340
EMD-22					
EMD-25	1100	2200	2100	1730	1630
EMD-32					

Control Box Operation(1)



Control Box Manual

Warning:

This electrical control box must be installed by a licensed or certified electrician or a qualified serviceman in accordance to the requirements of your government standard or local authorities. Improper installation will create electric hazards which could result in serious injury, death as well as damage to the property.

Before any servicing or maintenance work, make sure the electricity from the power supply had been switched off.

Control Box Operation(2)

Large Control Box Wiring Diagram

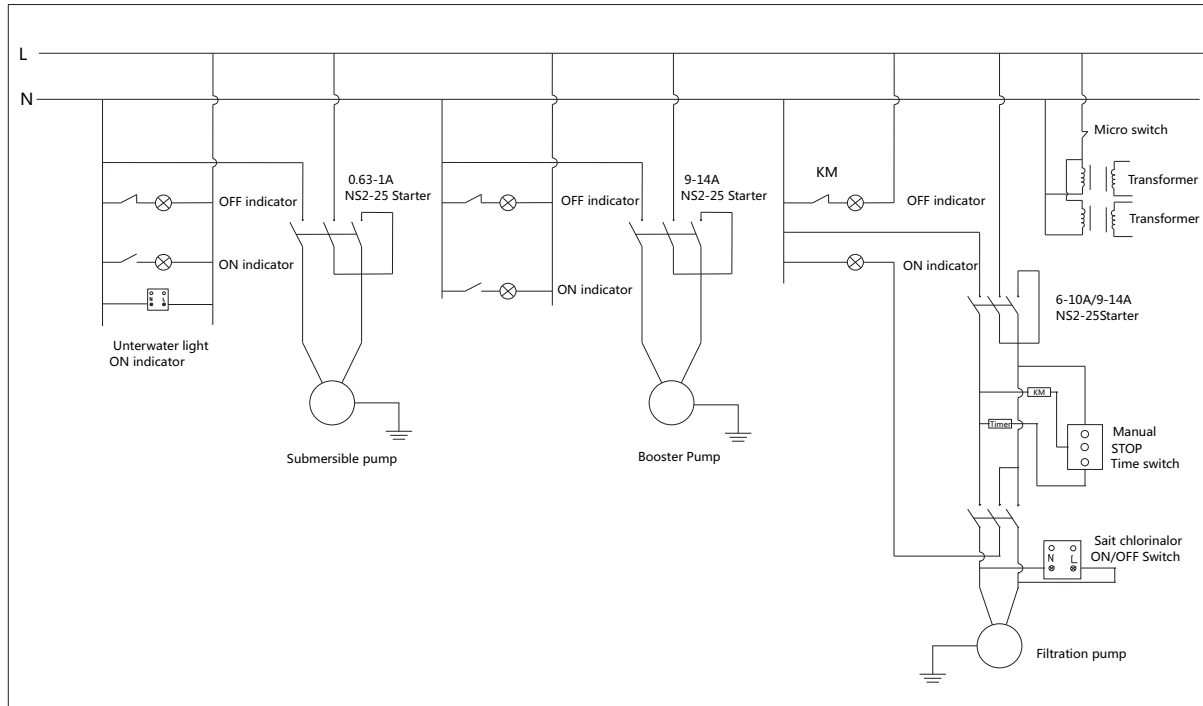

Control Box Operation(3)



Small Control Box Wiring Diagram

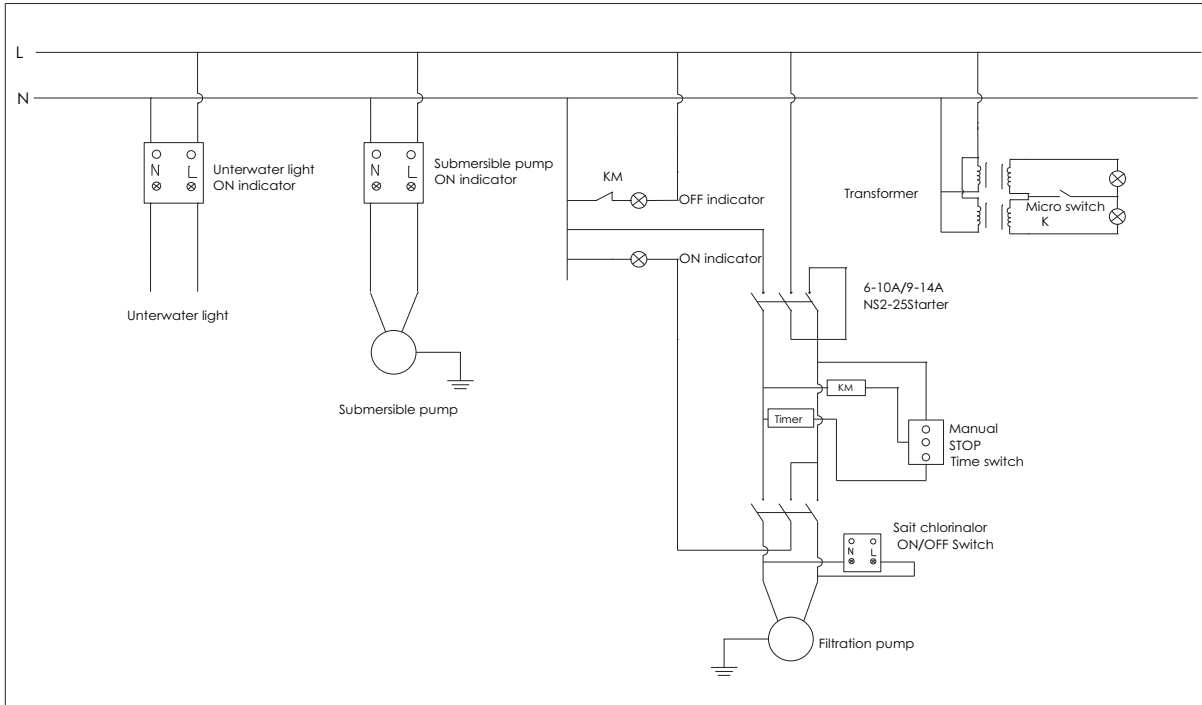

Control Box Operation(4)



Large Control Box Diagram

Small Control Box Diagram

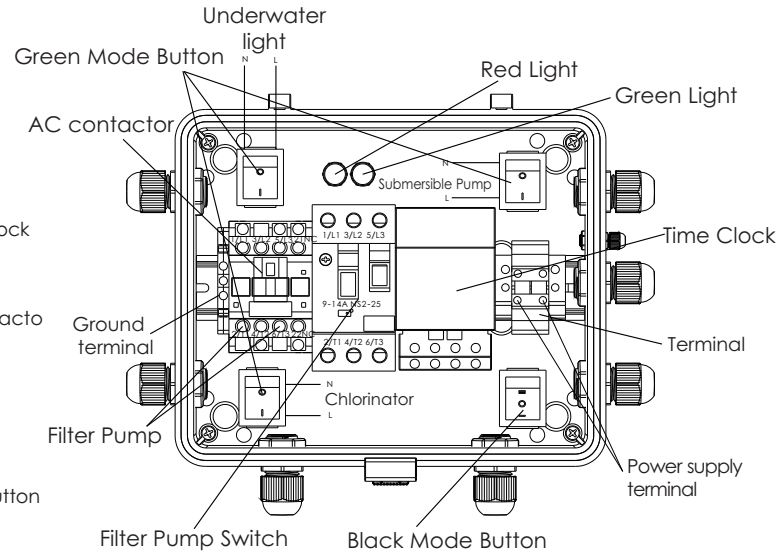
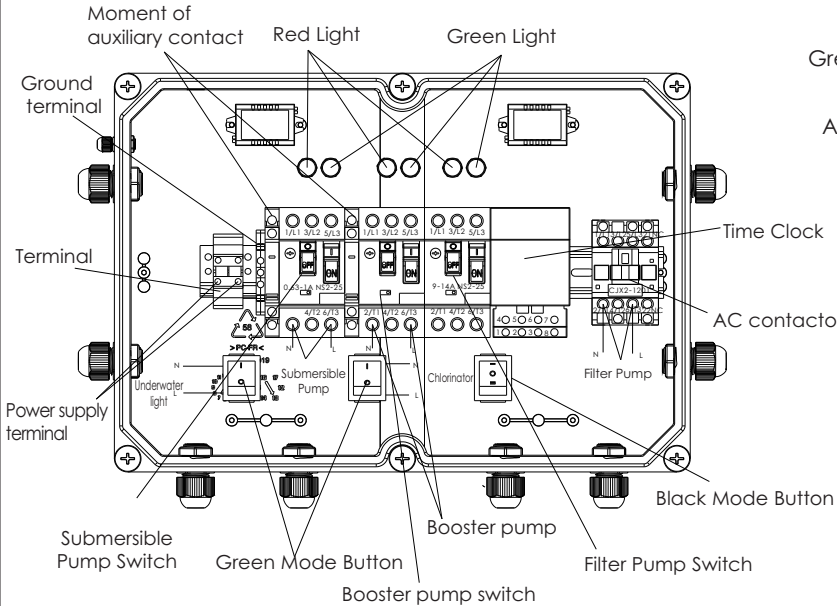

Control Box Operation(5)

Operation instruction:

1. Connecting the power supply, the AC motor starter switch to control the the massage pump on and off.

WARNING:Massage pump can not exceed the maximum input power 2.2KW!

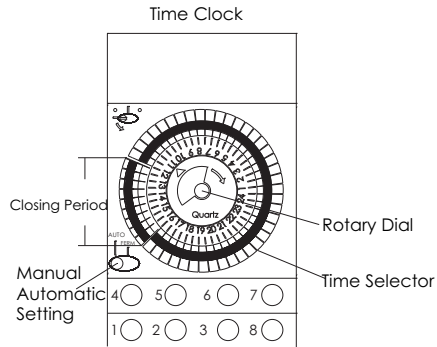

Operation instruction:

- 1) Connecting the power supply, the water light's starting and closing setting is controlled by the 1st green button switch.
- 2) Submersible pump switch should have been in the open state always, when there is some water level in the EMD box inside, the submersible pump will automatically start to work until the water level drops to a certain height.
- 3) Salt Chlorinator and filter pump are connecting, the main purpose is to protect the salt Chlorinator, the green button switch for controlling salt Chlorinator is suggesting to be in the opening position.
- 4) Filter pump system with three mode, automatic / stop / manual can be selected by black button switch.



- 5) Automatic mode: A. Ensure the Black button setting is on "automatic" for the MODE BUTTON B. Turn on the switch on the filter pump C. On the timer, select the "Automatic" setting, turn the Rotary Dial to the current time, depress the Time Selector tabs to set the turn-on, the triangle arrow to the time is switch time which you setting for close and work. D. Connecting the power supply, filter pump will be closed at this period time when dial selector is pull out, while it will be work in other period time.
- 6) Stop Mode: Ensure the setting is on "Stop" for the MODE BUTTON, filter pump will be in the closed state.
- 7) Manual mode: Ensure the setting is on "Manual" for the MODE BUTTON, The filter pump's starting and closing setting is controlled by the switch on the pump.

WARNING:

- 1) Filter pump, Submersible pump and Salt chlorinator which controlled by control box, that the maximum input power of filter pump must not exceed 1.3KW, the maximum input power of submersible pump must not exceed 0.2KW, the maximum input power of salt chlorinator and water light must not exceed 1.0KW.
- 2) Filter pump, Submersible pump and Salt chlorinator which controlled by control box, that the maximum input power of filter pump must not exceed 2.2KW, the maximum input power of submersible pump must not exceed 0.2KW, salt chlorinator and water light must not exceed 1.0KW.

Control Box Operation(6)

Large Control Box Part List



Item NO.	Part No.	Product Description	QTY
1	04014027	Black mode button	1
2	04014062	Green mode button	2
3	04014061	Green light	3
4	04014060	Rad light	3
5	04014112	Micro switch	1
6	03011352	M3*16 Flat Head Self-Tapping Screws	2
7	04012016	12V/1W Lamp with transformer	2
8	04014065	Moment of auxiliary contact	2
9	04014033	Earth connection	1
10	87010103	Wiring terminal fixed plate	1
	04014083	Wiring terminal patch	2
	04014108	Wiring terminal	2
11	04014066	AC motor starter(0.63-1A)	1
12	04014013	M8 PG 11 cable grand	5
	04014085	AVC NPT 1/2" cable grand	3
	04014085	PG7 cable grand	1
13	01360019	Control box body	1
14	03013001	M6 nut	4
	02011133	Rabbering(D10*6*2)	4
	03011320	Round machine screws (M6*20)	4
15	89390102	Cable	1
16	04014064	AC motor starter(9-14A)	1
17	04014063	AC contactor	1
18	04014029	Timer selector	1
19	04014030	AC motor starter(6-10A)	1
	04014064	AC motor starter(9-14A)	1
	04014019	Track	1
20	04014019	Track	1
21	01162023	Support plate	1
22	03011007	M4*12 Screws	10

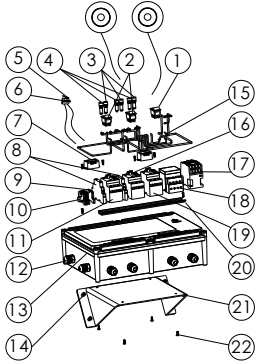

Control Box Operation(7)

Small Control Box Part List

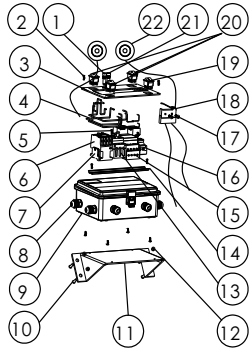

Item NO.	Part No.	Product Description	QTY				
1	04014060	Rad light	3	11	01169910	Support plate	1
2	03011007	M4*12 Screws	10	12	03013001	M6 nut	4
3	01321014	Control box panel	1	13	04014064	AC motor starter(9-14A)	1
4	89390102	Cable	1		04014030	AC motor starter(6-10A)	1
5	03011060	Round machine screws (M3*8)	4	14	04014019	Track	1
	03013025	Nut(M3)	4	15	04014029	Timer selector	1
	03012023	Cable	4	16	87010103	Wiring terminal fixed plate	1
6	04014063	AC contactor	1		04014083	Wiring terminal patch	2
7	04014033	Earth connection	1		04014108	Wiring terminal	2
8	04014013	M8 PG 11 cable grand	6	17	03011352	M3*16 Flat Head Self-Tapping Screws	2
	04014085	AVC NPT 1/2" cable grand	1	18	04014112	Micro switch	1
	04014085	PG7 cable grand	1	19	04014027	Black mode button	1
9	89480101	Control box body	1	20	04014062	Green mode button	3
10	02011133	Rubber ring(D10*6*2)	4	21	04014061	Green light	1
	03011320	Round machine screws (M6*20)	4	22	04012016	12V/1W Lamp with transformer	2

Filter Operation(1)

FUNCTION

The filter uses special filter sand to remove dirt particles from pool water. The filter sand is loaded into the filter tank and functions as the permanent dirt removing media. When the control valve is in the FILTER position, the pool water which contains suspended dirt particles, is pumped through your piping system and is automatically directed by the patented filter control valve to the top of the filter tank. As the pool water is pumped through the filter, dirt particles are trapped by the sand bed, and filtered out. The cleaned Pool water is returned from the bottom of the filter tank, through the control valve and back to the pool through the piping system. This entire sequence is continuous and automatic and provides for total recirculation of pool water through your filter and piping System.

After a period of time the accumulated dirt in the filter causes a resistance to flow, and the flow diminishes. This means it is time to clean your filter. With the control valve in the BACKWASH position, the water flow is automatically reversed through the filter so that it is directed to the bottom of the tank, up through the sand, flushing the previously trapped dirt and debris out the waste line. Once the filter is back-washed of dirt, set control valve to RINSE position and run pump for about 1/2 to 1 minute, and then to filter, to resume normal filtering.

NOTE: Turn pump off before changing valve position.

INSTALLATION

Only simple tools (screwdriver and wrenches), plus pipe sealant for plastic adapters, are required to install and service the filter.

- 1) The filter should be placed on a level concrete slab, very firm ground, or equivalent. Position the filter so that the piping connections, control valve are convenient and accessible for operation and service.

- 2) Loading the sand media.

Filter sand media is loaded through the top opening of the filter.

- a) Loosen flange clamp and remove filter control valve (if previously installed).
 - b) Cap internal pipe with plastic cap to prevent sand from entering it.
 - c) We recommend filling tank approximately 1/2 way with water to provide a cushion effect when the filter sand is poured in. This helps protect the under-drain laterals from excessive shock.
 - d) Carefully pour in correct amount and grade of filter sand. (Be sure center pipe remains centered in opening.) internal pipe. Sand surface should be leveled and should come to about the middle of the filter tank. Remove plastic cap from internal pipe.
- 3) Assemble filter control valve to filter tank.
 - a) Insert filter control valve (with O'ring in place) into the tank neck, ensuring the twelve bolts which is pre-embedded in the tank neck through the twelve hole round the valve, taking care that the center pipe slips into the hole in the bottom of the valve as well.
 - b) Put the twelve nuts and washers onto each of the twelve bolts, then screw all the nuts on with wrench, ensuring that all nuts are tight.
 - c) Carefully screw pressure gauge (with O'ring in place) into tapped hole in valve body. Do not over-tighten.
 - d) Connect pump to control valve opening marked PUMP.
 - 4) Make return to pool pipe connection to control valve opening marked RETURN and complete other necessary plumbing connections, suction lines to pump, waste, etc.
 - 5) Make electrical connections to pump per pump instructions.
 - 6) To prevent water leakage, be sure all pipe connections are tight.



Filter Operation(2)

INSTALL/START-UP OF FILTER

- 1) Be sure correct amount of filter media sand is in tank and that all connections have been made and are secure.
- 2) Depress control valve handle and rotate to BACKWASH position. (To prevent damage to control valve seal, always depress handle before turning.)
- 3) Prime and start pump according to pump instructions (be sure all suction and return lines are open), allowing the filter tank to fill with water. Once water is flowing out of the waste line, run the pump for at least 1 minute. The initial back- washing of the filter is recommended to remove any impurities or fine sand particles in the sand media.
- 4) Turn pump off and set valve to RINSE position. Start pump and operate until water in sight glass is clear, about 1/2 to 1 minute. Turn pump off and set valve to FILTER position and restart pump. The filter is now operating in the normal filter mode, filtering dirt particles from the pool water.
- 5) Adjust pool suction and return valves to achieve



desired flow. Check system and filter for water leaks and tighten connections, bolts, nuts, as required.

Note the initial pressure gauge reading when the filter is clean. (It will vary from pool to pool depending upon the pump and general piping system.) As the filter removes dirt and impurities from the pool water, the accumulation in the cause the pressure to rise and flow to diminish. When the pressure gauge reading is 1.5 bar, higher than the initial "clean" pressure you noted, it is time to backwash the filter (see BACKWASH under filter and control valve functions).

NOTE: During initial clean-up of the pool water it may be necessary to backwash frequently due to the unusually heavy initial dirt load in the water.

Filter Operation(3)

Key No.	Part No.	Product Description	Qty
1	89010701	Air Release Valve	1
2	06011032	Oil Pressure Gauge With O-ring (40 psi)	1
3	01111048	Connector for Pressure Gauge/Stopper	1
4	01201022	Lid (Transparent)	1
5	89010119	M6*50 Screws With Nut	2
	01271010	Clamp Lock	2
6	02011134	O-Ring for Filter Neck	1
7	89010706	S450 Filter tank	1
	89010705	S500 Filter tank	1
	89010704	S650 Filter tank	1
	89010703	S700 Filter tank	1
8	88280805	1.5" Side Mount Valve	1
9	89010707	Connector Plate Side Mount	1
10	89010708	S450 Top part of the inner tank system	1
	89010709	S500 Top part of the inner tank system	1
	89010710	S650 Top part of the inner tank system	1
	89010711	S700 Top part of the inner tank system	1
11	01111046	Tank System Support	1
12	89010712	S450 bottom part of the inner tank system	1
	89010713	S500 bottom part of the inner tank system	1
	89010714	S650 bottom part of the inner tank system	1
	89010715	S700 bottom part of the inner tank system	1
	13	01172007	S450 Laterals (115mm)
01172008		S500-S700 Laterals (126mm)	8
14	89010107	Water Drain Set	1
15	01111059	S450 Filter Base	1
	01111062	S500-S700 Filter Base	1
16	01181052	Fastener for Filter Base	4
17	89010716	S450 Air Vent Pipe	1
	89010717	S500 Air Vent Pipe	1
	89010718	S650 Air Vent Pipe	1
	89011205	S700 Air Vent Pipe	1

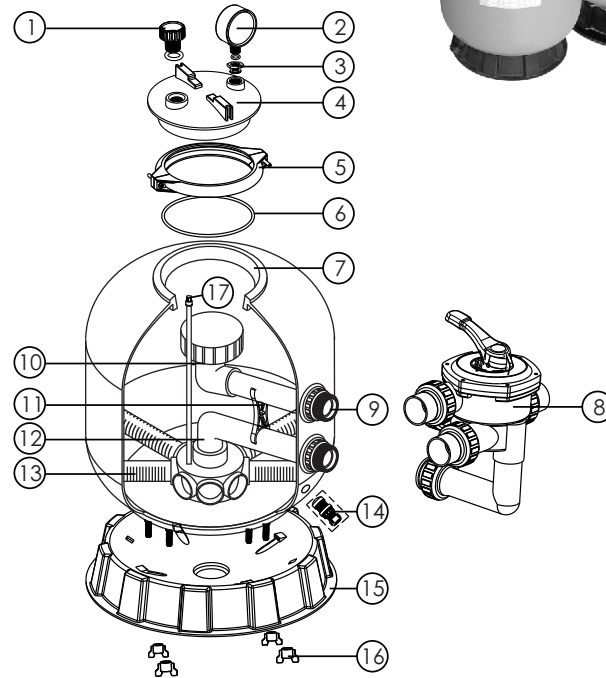

Filter Operation(4)

Key No.	Part No.	Product Description	Qty
1	06011032	Oil Pressure Gauge With O-ring (40 psi)	1
	01111048	Connector for Pressure Gauge/Stopper	1
2	89010701	Air Release Valve	1
3	89010601	03013003 M8 Nut*12Pc; + 03012003 M8 Washer*12Pc;	1
4	01172005	Lid (Grey Colour)	1
5	02011126	Filter Neck Gasket	1
6	89011202	S700B Filter Tank With Base	1
	89011208	S800 Filter Tank With Base	1
	89011209	S900 Filter Tank With Base	1
7	88280806	2. 0"Side Mount Valve	1
8	89011201	Connector Plate Side Mount	1
9	89011203	S700B Top part of the inner tank system	1
	89011210	S800 Top part of the inner tank system	1
	89011211	S900 Top part of the inner tank system	1
10	89011204	S700B Bottom part of the inner tank system	1
	89011212	S800 Bottom part of the inner tank system	1
	89011213	S900 Bottom part of the inner tank system	1
11	01172011	Laterals (233mm)	8
12	01111090	Tank System Support	1
13	89011205	S700B Air Vent Pipe	1
	89011206	S800 Air Vent Pipe	1
	89011207	S900 Air Vent Pipe	1
14	89010107	Water Drain Set	1

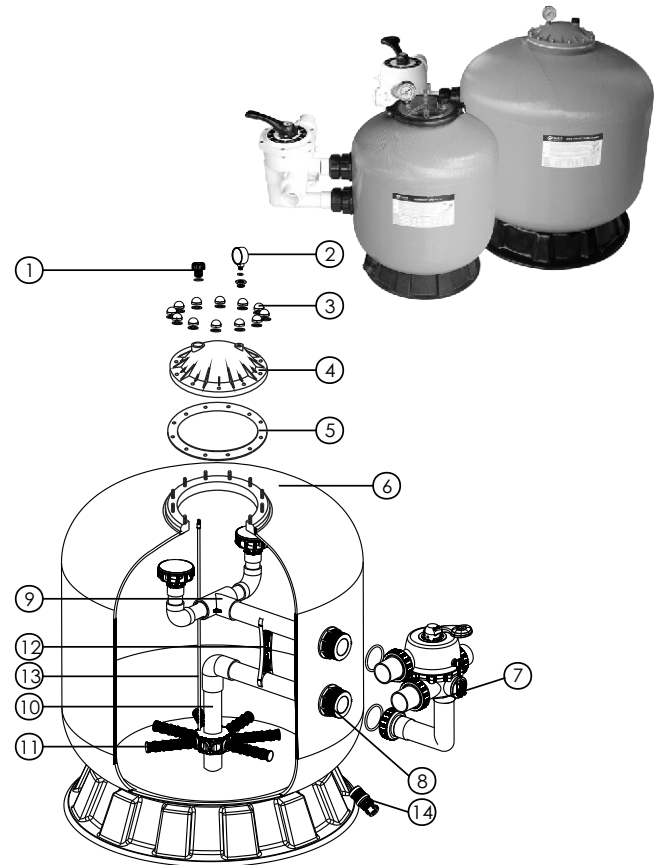

Filter Operation(5)

Key No.	Part No.	Product Description	Qty
1	01013002	Handle (Small)	1
2	03018008	Pin for Handle	1
3	01181001	Washer for Handle	1
4	89281203	M6×25 Screw with Nut for Camber Lid	6
	89280107	M6×30 Screw with Nut for Standard Lid	6
5	01051010	1. 5" Side Mount Valve Standard Lid (White)	1
6	02011022	O-Ring for 1. 5" Valve Rotor	2
7	01181002	Washer for Spring	1
8	02011002	O-Ring for 1. 5" Valve Lid	1
9	03014001	Spring for 1. 5" Simd Mount Valve	1
10	01021001	1. 5" Valve Rotor	1
11	02311002	Spider Gasket	1
12	01051021	1. 5" Side Mount Valve Bottom Body (White)	1
13	01111048	Connector for Pressure Gauge/Stopper	1
14	89021303	Drain Plug with O-ring	1
15	06011032	Oil Pressure Gauge with O-ring (40Psi)	1
16	02020013	O-Ring	5
17	01051022	1. 5" Union Tale (White)	1
18	01013017	1. 5" Union Nut (Black)	5
19	89280104	Sight Glass with O-Ring	1
20	01051023	1. 5" Side Mount Valve Plug (White)	1
21	01051193	1. 5" Elbow Tube (White) 120mm	1
22	01171002	1. 5" Union Adaptor (Metric)	1
23	01051013	1. 5" Connector with External Thread(White)	3
24	02011003	O-Ring $\phi 59 \times \phi 53 \times \phi 3$	5
25	01171153	1. 5" Union Adaptor	3

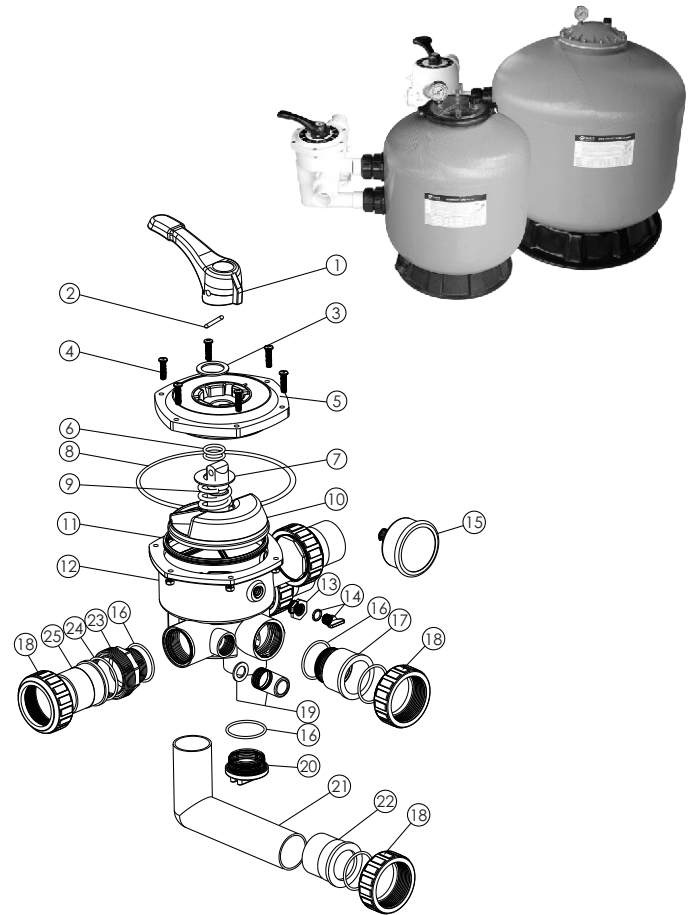

Filter Operation(6)

Key No.	Part No.	Product Description	Qty
1	01013003	Handle (Big)	1
2	03018008	Pin for Handle	1
3	01181027	Washer for Handle	1
4	01051026	2.0" Side Mount Valve Squareness Lid (White)	1
5	89280301	M6*32 Screw with Nut	10
6	01111048	Connector for Pressure Gauge/Stopper	1
7	89021303	Drain Plug with O' Ring	1
8	06011029	Oil Pressure Gauge With O-ring (40psi)	1
9	02020016	O-Ring for 2.0" Union	8
10	01051033	2.0" Connector (White)	3
11	01171154	2.0" Union (A/E)	3
12	01051032	2.0" Union Nut (White)	3
13	02011009	O-Ring for 2.0" Valve Lid	1
14	01181002	Washer for spring	1
15	02011022	O-Ring for 2.0" Valve Rotor	2
16	03014014	Spring	1
17	01021002	2.0" Valve Rotor	1
18	02311003	Spider Gasket	1
19	01051027	2.0" Side Mount Valve Bottom Body (White)	1
20	89280104	Sight Glass With O-Ring	1
21	02011011	O-Ring for Union Tale	1
22	01051035	2.0" Union Tale (White)	1
23	01013034	2.0" Union Nut (Black)	2
24	02020017	O-Ring for Plug	1
25	01051029	2.0" Side Mount Valve Plug (White)	2
26	01051195	2.0" Elbow Tube (White) 183mm	1
27	01171035	2.0" Union Adaptor (Metric)	1

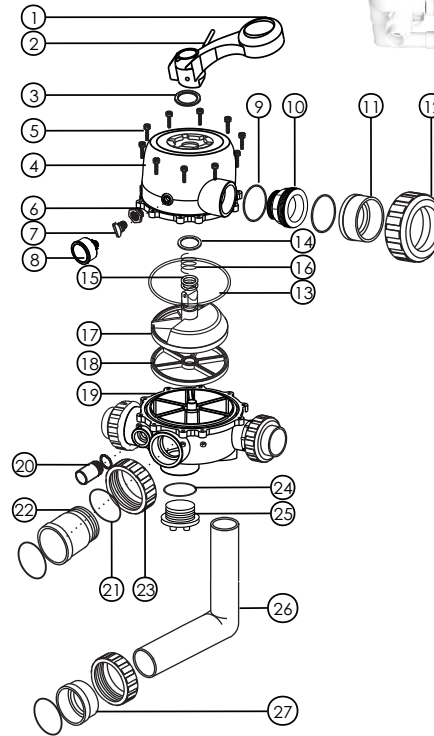

Filter Operation(7)

GENERAL

- 1) Pipe tap boss provided for optional influent pressure gauge.
- 2) SERVICING VALVE(Stop pump,close gate valve in suction & discharge before proceeding):
 - a) Set handle in filter position.
 - b) Remove cover screws.
 - c) Lift cover and key assembly out.

TO ASSEMBLE:

- 1) Place valve key so that wedge opening is at TOP port (handle in Filter psn.). Flat edge of cover screw lug should align with flat edge of body screw lug.
- 2) Position cover O'Ring.
- 3) Secure assembly to body with cover screws. Tighten cover screws evenly and alternately. Do not over-tighten.



WARNING

THIS FILTER OPERATES UNDER HIGH PRESSURE. WHEN ANY PART OF THE CIRCULATING SYSTEM (e.g., CLAMP, PUMP, FILTER, VALVES, ETC.) IS SERVICED, AIR CAN ENTER THE SYSTEM AND BECOME PRESSURIZED . PRESSURIZED AIR CAN CAUSE THE LID OR VALVE TO BE BLOWN OFF WHICH CAN RESULT IN SEVERE INJURY, DEATH, OR PROPERTY DAMAGE. DO NOT UNSCREW SCREWS OF FLANGE CLAMP WHILE FILTER OPERATING. TURN PUMP OFF BEFORE CHANGING VALVE POSITION. TO PREVENT DAMAGE TO THE PUMP AND FOR PROPER OPERATION OF THE SYSTEM, CLEAN PUMP STRAINER AND SKIMMER BASKETS REGULARLY.

Filter Operation(8)

FUNCTIONS OF VALVE POSITIONS

Valve Position	Function
FILTER	Normal Filtration
BACKWASH	Cleaning Filter by reversing the flow
RINSE	Used after backwash to flush dirt from valve
WASTE	By-passes filter, used for vacuuming to waste or lowering water level
RECIRCULATE	By-passes filter for circulating water to pool
CLOSED	Shuts off all flow to filter or pool



MAIN DIMENSION

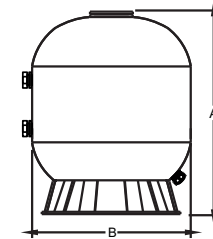

Model	High mm A	Diameter mm B	Valve inch	Sand kg
S450	730	455	1.5"	45
S500	770	535	1.5"	85
S650	850	635	1.5"	145
S700	960	710	1.5"	210
S700(B)	960	723	2"	215
S800	1050	820	2"	355
S900	1180	920	2"	470

FILTER

WASTE

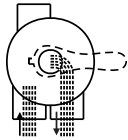

IN FLOW OUT FLOW

WASTE

WASTE

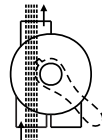

IN FLOW OUT FLOW

CLOSED

WASTE

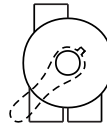

IN FLOW OUT FLOW

BACKWASH

WASTE

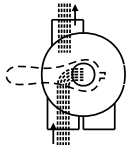

IN FLOW OUT FLOW

RINSE

WASTE

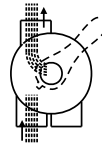

IN FLOW OUT FLOW

RECIRCULATE

WASTE



IN FLOW OUT FLOW

Pump Operation(1)

Before installation, be sure to read all instructions and warnings carefully.

Refer to product data plate(s) for additional operating instruction and specifications.

INSPECTION

Examine the equipment when received. Notify your dealer or carrier of any damage or missing parts. Verify that equipment is of size and model specified.

IMPORTANT SAFETY INSTRUCTIONS

When installing and using this electrical equipment, basic safety precautions should always be followed, including the following:

- 1) READ AND FOLLOW ALL INSTRUCTIONS.
- 2) WARNING — To reduce risk of injury, do not permit children to use this product unless they are closely supervised at all times.
- 3) WARNING — (For cord & plug connected units) risk of electric shock. Connect only to a grounding type receptacle protected by a ground-fault circuit-interrupter(GFCI). Contact a qualified electrician if you cannot verify that the receptacle is protected by a GFCI.
- 4) WARNING — (For cord & plug connected units). To reduce the risk of electric shock, replace damaged cord immediately.
- 5) WARNING — (For cord & plug connected units). To reduce the risk of electric shock do not use an extension cord to connect unit to electric supply; Provide a properly located outlet.
- 6) WARNING — (For hottubandspa pumps). Do not install within an outer enclosure or beneath the skirt of the hot tub or spa, unless so marked.
- 7) SAVE THESE INSTRUCTIONS



INSTALLATION LOCATION

Locate pump as close to pool/spa as possible, preferably in a dry, well ventilated area away from direct sunlight, it should be on a hard, level surface. Give consideration to:

- 1) Drainage — away from pump
- 2) Ventilation of pump motor
- 3) Access for future servicing and winterizing
- 4) Protection from the elements Pumps without strainer bodies are designed for flooded suction (all suction fittings and suction piping below water level) and will not self-prime. Consequently, the pump must be installed at an elevation that is below water level when pool or spa is filled.

GENERAL PLUMBING

FOR SOLVENT WELD CONNECTION

Rigid or flexible PVC pipe can be used. Pipe ends should be clean and free of

Pump Operation(2)

any flash caused by the cutting operation. Be sure that the proper solvent is used on type of pipe specified.

Caution: We recommend that consider climatic conditions when applying adhesives, make the adhesive action of certain glues less effective. Check the manufacturer's instructions.

PUMP PLUMBING

Suction pipe should be as large or large than discharge pipe avoid using a suction pipe smaller than pump connection. Keep the piping as straight and short as possible, and of suitable size. Avoid connecting an elbow directly into the pump inlet (use a length of straight pipe to allow a proper entry for the water). arrange horizontal runs to slope upward to the pump to prevent high spots that could form air pockets. Support the piping independently so that it places no strain on the pump. Keep as much of the suction line as possible below the water level to reduce priming time.

ELECTRICAL DATA

Refer to information on motor nameplate for electrical service data. All motors should have fused disconnect switch or circuit breaker. Be sure wire size is sufficient for pump hp and distance from power source. Wiring should be done in accordance with applicable codes by a competent electrician.

PUMP START UP

Do not operate pump until it has been primed as water acts to cool and lubricate the seal. For pumps without strainer bodies and located above water, close suction line valve and fill pump with water in order to prime. If no flow is observed in five minutes, stop the motor and re-prime. If the pump fails to operate, check for air



leaks. Refer to trouble shooting section.

PUMP MAINTENANCE

- 1) Motors are self-lubricating no lubrication required.
- 2) Shaft seals may become worn and must be replaced if leakage is observed

SERVICE & REPAIR PARTS

Refer all service to your local dealer as his knowledge of your equipment makes him the best qualified source of information. Order all repair parts through your dealer. Give the following information when ordering repair parts:

- 1) Unit nameplate data.
- 2) Description of part.

TROUBLESHOOTING

MOTOR DOES NOT START

- 1) Disconnect switch or circuit breaker in off position
- 2) Fuses blown or thermal overload open
- 3) Locked motor shaft
- 4) Motor windings burned out
- 5) Defective starting switch inside single phase motor
- 6) Disconnected or defective wiring
- 7) Low voltage

Pump Operation(3)

NOISY PUMP AND MOTOR

- 1) Worn motor bearings
- 2) Suction line partly plugged

MOTOR OVERHEATS

- 1) Low voltage
- 2) Inadequate ventilation

AIR BUBBLES AT INLET FITTINGS

- 1) Leakage of air into suction line at connections or valve stem
- 2) Low water level in drain of bath 1.

LOW PUMP CAPACITY

- 1) Suction or discharge line partly plugged
- 2) Suction or discharge line too small
- 3) Pump running at reduced speed
- 4) Impeller clogged

HIGH PUMP PRESSURE

Return lines too small

PUMP DOES NOT REACH FULL SPEED

- 1) Low voltage.
- 2) Pump connected for wrong voltage.

PUMP DELIVERS NO WATER

- 1) Pump is not primed
- 2) Leakage or air into suction system

- 3) Impeller clogged

LEAKAGE OF WATER AT SHAFT

Shaft seal requires replaceme

NOTE: If the recommendations in the trouble shooting portion of this manual do not solve your particular problem(s), please contact your local dealer for service.



Pump Operation(4)

SB Series Pump SB

Key No.	Part No.	Product Description	Qty	Key No.	Part No.	Product Description	Qty
1	01021008	Nut for lid	1	19	02011101	Motor Slinger for SB20;SB30	1
2	01041022	Transparent Lid	1	89021301	Motor SB10 (220V /50Hz)	1	
3	02011085	O-Ring for lid	1	89021302	Motor SB15 (220V /50Hz)	1	
4	01111030	Basket	1	89021303	Motor SB20 (220V /50Hz)	1	
5	89021305	Pre-filter body	1	89021304	Motor SB30 (220V /50Hz)	1	
6	89280103	2. 0" Union	2	89021401	Motor SB10 (220V /60Hz)	1	
7	89021307	Drain Plug With O-ring	1	89021402	Motor SB15 (220V /60Hz)	1	
8	02011115	Square gasket	1	89021403	Motor SB20 (220V /60Hz)	1	
9	03011083	M6*30 Screw for pump body	4	89021404	Motor SB30 (220V /60Hz)	1	
10	89021308	SB Pump body	1	89021601	Motor SB10 (380V /50Hz)	1	
11	89021309	Screw for impeller with O-ring	1	89021602	Motor SB15 (380V /50Hz)	1	
12	02011108	O-Ring for diffuser	1	89021603	Motor SB20 (380V /50Hz)	1	
13	01111015	Diffuser	1	89021604	Motor SB30 (380V /50Hz)	1	
14	01311004	Impeller SB10 (220V /50Hz)	1	89021501	Motor SB10 (110V /60Hz)	1	
	01311005	Impeller SB15 (220V /50Hz)	1	89021502	Motor SB15 (110V /60Hz)	1	
	01311003	Impeller SB20 (220V /50Hz)	1	89021503	Motor SB20 (110V /60Hz)	1	
	01311006	Impeller SB30 (220V /50Hz)	1	89021504	Motor SB30 (110V /60Hz)	1	
	01311001	Impeller SB10 (220V /60Hz)	1	21	89021310	M8*20 Bolt for motor with washer	4
	01311004	Impeller SB15 (220V /60Hz)	1	22	01021021	Opening key	1
	01311002	Impeller SB20 (220V /60Hz)	1	23	01111032	Base with nut & washer for SB10;SB15	1
	01311005	Impeller SB30 (220V /60Hz)	1	23	01111031	Base with nut & washer for SB20;SB30	1
	01311004	Impeller SB10 (380V /50Hz)	1	24	89021312	Cable Box for SB Pump 220V /50Hz;220V /60Hz;380V /50Hz.	1
	01311005	Impeller SB15 (380V /50Hz)	1	25	89021505	Cable Box for SB Pump 110V /60Hz	1
	01311003	Impeller SB20 (380V /50Hz)	1	26	01031001	Fan Cover for SB20, SB30 Pump	1
	01311006	Impeller SB30 (380V /50Hz)	1	26	01031002	Fan Cover for SB10, SB15 Pump	1
	01311001	Impeller SB10 (110V /60Hz)	1	27	01031008	Fan Cover for SB20, SB30 Pump	1
	01311004	Impeller SB15 (110V /60Hz)	1	27	01031009	Fan Cover for SB10, SB15 Pump	1
01311002	Impeller SB20 (110V /60Hz)	1	28	01031007	Cooling fan for SB10, SB15 Pump	1	
01311005	Impeller SB30 (110V /60Hz)	1	28	01031006	Cooling fan for SB20, SB30 Pump	1	
15	04015032	3/4" Mechanical seal	1	29	04016014	Capacitor for SB10, SB15 Pump	1
16	02011093	O-Ring for flange	1	29	04016015	Capacitor for SB20 Pump	1
17	01021013	SB Pump Flange	1	29	04016016	Capacitor for SB30 Pump	1
18	03011080	M6*15 Hexagonal Bolt	16	29	04016022	Capacitor for SB10, SB15 Pump	1
19	02011099	Motor Slinger for SB10;SB15	1	29	04016023	Capacitor for SB20, SB30 Pump	1

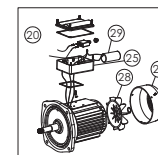
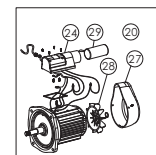
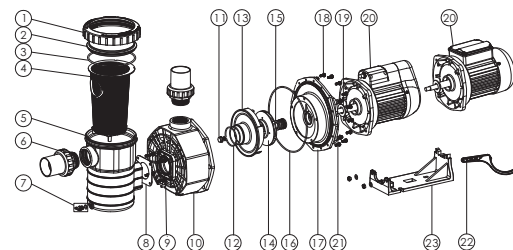

Pump Operation(5)

SC Series Pump SC

Key No.	Part No.	Product Description	Qty	Key No.	Part No.	Product Description	Qty
1	01041043	Transparent Lid	1	16	89021706	Motor SC075 (220V/50Hz)	1
2	02011077	O-Ring for lid	1		89021707	Motor SC100 (220V/50Hz)	1
3	01111076	Basket	1		89021708	Motor SC150 (220V/50Hz)	1
4	89280105	1. 5" union	2		89021709	Motor SC200 (220V/50Hz)	1
5	89021307	Drain Plug With O-ring	1		89021801	Motor SC050 (220V/60Hz)	1
6	01111006	SC Pump Body	1		89021802	Motor SC075 (220V/60Hz)	1
7	02011105	O-ring for Diffuser	1		89021803	Motor SC100 (220V/60Hz)	1
8	01111009	Diffuser	1		89021804	Motor SC150 (220V/60Hz)	1
9	89021309	Impeller Screw with O-ring	1		89021805	Motor SC200 (220V/60Hz)	1
10	01311009	Impeller SC050 (220V/50Hz)	1		89022001	Motor SC050 (380V/50Hz)	1
	01311010	Impeller SC075 (220V/50Hz)	1		89022002	Motor SC075 (380V/50Hz)	1
	01311011	Impeller SC100 (220V/50Hz)	1		89022003	Motor SC100 (380V/50Hz)	1
	01311012	Impeller SC150 (220V/50Hz)	1		89022004	Motor SC150 (380V/50Hz)	1
	01311013	Impeller SC200 (220V/50Hz)	1		89022005	Motor SC200 (380V/50Hz)	1
	01311007	Impeller SC050 (220V/60Hz)	1		89021901	Motor SC050 (110V/60Hz)	1
	01311008	Impeller SC075 (220V/60Hz)	1		89021902	Motor SC075 (110V/60Hz)	1
	01311009	Impeller SC100 (220V/60Hz)	1	89021903	Motor SC100 (110V/60Hz)	1	
	01311010	Impeller SC150 (220V/60Hz)	1	89021904	Motor SC150 (110V/60Hz)	1	
	01311011	Impeller SC200 (220V/60Hz)	1	89021905	Motor SC200 (110V/60Hz)	1	
	01311009	Impeller SC050 (380V/50Hz)	1	17	01021022	Opening Key	1
01311010	Impeller SC075 (380V/50Hz)	1	18	01111007	SC Pumps Base	1	
01311011	Impeller SC100 (380V/50Hz)	1	19	89021311	Cable Box for SC Pump	1	
01311012	Impeller SC150 (380V/50Hz)	1	20	89021505	Cable Box for SC Pump	1	
01311013	Impeller SC200 (380V/50Hz)	1	21	04016019	Capacitor for SC050 Pump	1	
01311007	Impeller SC050 (110V/60Hz)	1		04016021	Capacitor for SC075 Pump	1	
01311008	Impeller SC075 (110V/60Hz)	1		04016022	Capacitor for SC100-SC150 Pump	1	
01311009	Impeller SC100 (110V/60Hz)	1		04016023	Capacitor for SC200 Pump	1	
01311010	Impeller SC150 (110V/60Hz)	1		04016010	Capacitor for SC050 Pump	1	
01311011	Impeller SC200 (110V/60Hz)	1		04016012	Capacitor for SC075 Pump	1	
11	04015032	3/4" Mechanical seal		1	04016014	Capacitor for SC100-SC150 Pump	1
12	02011089	O-ring for Flange	1	04016015	Capacitor for SC200 Pump	1	
13	01111008	SC Pump Flange	1	22	01031007	Cooling fan for SC Pump	1
14	01021014	Ring Lock Nut	1	23	01031009	Fan Cover	1
15	02011096	Motor Slinger	1	24	01031002	Fan Cover	1
16	89021705	Motor SC050 (220V/50Hz)	1	25	02011104	O-Ring	2

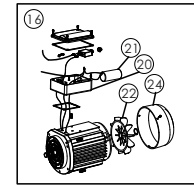
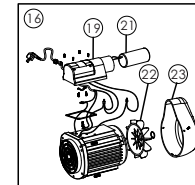
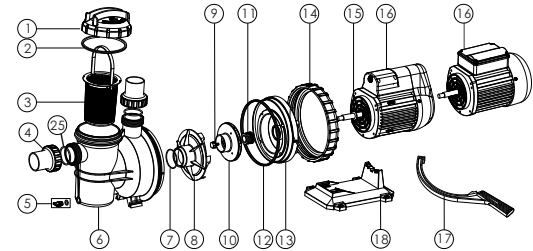

Pump Operation(6)

SS Series Pump SS

Key No.	Part No.	Product Description	Qty	Key No.	Part No.	Product Description	Qty
1	01201031	Transparent Lid	1	17	89022110	Motor SS033 (220V/50Hz)	1
2	02011074	O-Ring for lid	1		89022105	Motor SS050 (220V/50Hz)	1
3	89022401	Basket with Handle	1		89022106	Motor SS075 (220V/50Hz)	1
4	01021064	SS Pump Pre-filter	1		89022107	Motor SS100 (220V/50Hz)	1
5	89280105	1.5" union	2		89022108	Motor SS120 (220V/50Hz)	1
6	89022402	Drain Plug With O' ring	1		89022201	Motor SS020 (220V/60Hz)	1
7	02011004	O-Ring for diffuser	1		89022202	Motor SS033 (220V/60Hz)	1
8	01111014	Diffuser	1		89022203	Motor SS050 (220V/60Hz)	1
9	01311015	Impeller SS020 (220V/50Hz)	1		89022204	Motor SS075 (220V/60Hz)	1
	01311016	Impeller SS033 (220V/50Hz)	1		89022205	Motor SS100 (220V/60Hz)	1
	01311017	Impeller SS050 (220V/50Hz)	1		89022206	Motor SS120 (220V/60Hz)	1
	01311018	Impeller SS075 (220V/50Hz)	1		89022305	Motor SS020 (110V/60Hz)	1
	01311019	Impeller SS100 (220V/50Hz)	1		89022306	Motor SS033 (110V/60Hz)	1
	01311014	Impeller SS120 (220V/50Hz)	1		89022301	Motor SS050 (110V/60Hz)	1
	01311023	Impeller SS020 (220V/60Hz)	1		89022302	Motor SS075 (110V/60Hz)	1
	01311024	Impeller SS033 (220V/60Hz)	1		89022303	Motor SS100 (110V/60Hz)	1
	01311015	Impeller SS050 (220V/60Hz)	1		89022304	Motor SS120 (110V/60Hz)	1
	01311016	Impeller SS075 (220V/60Hz)	1	04016028	Capacitor for SS050 Pump	1	
	01311017	Impeller SS100 (220V/60Hz)	1	04016019	Capacitor for SS075 Pump	1	
	01311018	Impeller SS120 (220V/60Hz)	1	04016021	Capacitor for SS100 Pump	1	
	10	01311023	Impeller SS020 (110V/60Hz)	1	04016009	Capacitor for SS050 Pump	1
01311024		Impeller SS033 (110V/60Hz)	1	04016010	Capacitor for SS075 Pump	1	
01311015		Impeller SS050 (110V/60Hz)	1	04016012	Capacitor for SS100 Pump	1	
01311016		Impeller SS075 (110V/60Hz)	1	04016032	Capacitor for SS020 Pump	1	
01311017		Impeller SS100 (110V/60Hz)	1	04016033	Capacitor for SS033 Pump	1	
01311018		Impeller SS120 (110V/60Hz)	1	04016030	Capacitor for SS020 Pump	1	
04016031		Capacitor for SS033 Pump	1	04016031	Capacitor for SS033 Pump	1	
11	04015033	1/2" Mechanical seal	1	19	89022112	Cable Box for SS050-SS120 Pump	1
12	02011090	O-Ring for Flange	1	20	89022111	Cable Box for SS020-SS033 Pump	1
13	01021065	SS Pump Flange	1	21	89021505	Cable Box for SS050-SS075 Pump	1
14	03011035	M6*30 Screw	8	22	01031027	Cooling fan for SS050-SS120 Pump	1
15	02011156	Motor Slinger for SS020:SS033	1	22	01031026	Cooling fan for SS020-SS033 Pump	1
15	02011153	Motor Slinger for SS050-SS120	1	23	01031011	Fan Cover for SS020-SS033 Pump	1
16	89022404	Motor support	1		01031010	Fan Cover for SS050-SS120 Pump	1
17	89022109	Motor SS020 (220V/50Hz)	1		24	02011104	O-Ring

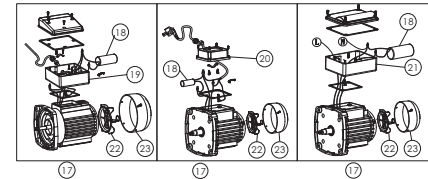
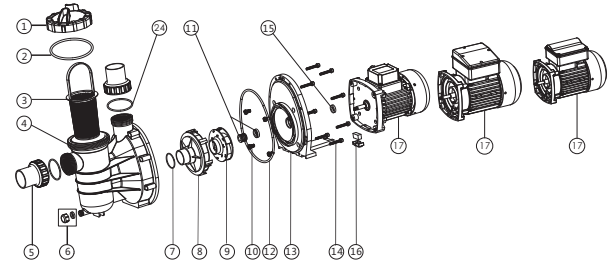

Pump Operation(7)

SR Series Pump SR

Key No.	Part No.	Product Description	Qty	Key No.	Part No.	Product Description	Qty
1	89280306	2. 0" Union	2	13	89021304	Motor SR300 (220V /50Hz)	1
2	89023601	Connecting	1		89021401	Motor SR100 (220V /60Hz)	1
3	89021308	SR Pump body	1		89021402	Motor SR150 (220V /60Hz)	1
4	89021309	Screw for impeller with O-ring	1		89021403	Motor SR200 (220V /60Hz)	1
5	02011108	O-Ring for diffuser	1		89021404	Motor SR300 (220V /60Hz)	1
6	01111015	Diffuser	1		89021601	Motor SR100 (380V /50Hz)	1
	01311004	Impeller SR100 (220V /50Hz)	1		89021602	Motor SR150 (380V /50Hz)	1
	01311005	Impeller SR150 (220V /50Hz)	1		89021603	Motor SR200 (380V /50Hz)	1
	01311003	Impeller SR200 (220V /50Hz)	1		89021604	Motor SR300 (380V /50Hz)	1
	01311006	Impeller SR300 (220V /50Hz)	1		89021501	Motor SR100 (110V /60Hz)	1
	01311001	Impeller SR100 (220V /60Hz)	1		89021502	Motor SR150 (110V /60Hz)	1
	01311004	Impeller SR150 (220V /60Hz)	1		89021503	Motor SR200 (110V /60Hz)	1
7	01311002	Impeller SR200 (220V /60Hz)	1		89021504	Motor SR300 (110V /60Hz)	1
	01311005	Impeller SR300 (220V /60Hz)	1	89021310	M8×20 Screw for motor with washer	4	
	01311004	Impeller SR100 (380V /50Hz)	1	01111032	Base with nut & washer for SR100;SR150	1	
	01311005	Impeller SR150 (380V /50Hz)	1	01111031	Base with nut & washer for SR200;SR300	1	
	01311003	Impeller SR200 (380V /50Hz)	1	01021021	Opening key	1	
	01311006	Impeller SR300 (380V /50Hz)	1	04016014	Capacitor for SR100, SR150 Pump	1	
	01311001	Impeller SR100 (110V /60Hz)	1	04016015	Capacitor for SR200 Pump	1	
	01311004	Impeller SR150 (110V /60Hz)	1	04016016	Capacitor for SR300 Pump	1	
	01311002	Impeller SR200 (110V /60Hz)	1	04016022	Capacitor for SR100, SR150 Pump	1	
	01311005	Impeller SR300 (110V /60Hz)	1	04016023	Capacitor for SR200, SR300 Pump	1	
8	04015001	3/4" Mechanical seal	1	18	89021505	Cable Box for SR Pump 110V /60Hz	1
9	02011093	O-Ring for flange	1	19	89021312	Cable Box for SR Pump 220V/50Hz; 220V/60Hz;380V/50Hz	1
10	01021013	SR Pump Flange	1				
11	03011080	M6×15 Hexagonal screw	16	20	01031007	Cooling fan for SR100, SR150 Pump	1
12	02011099	Motor Slinger for SR100;SR150	1		01031006	Cooling fan for SR200, SR300 Pump	1
	02011101	Motor Slinger for SR200;SR300	1		01031001	Fan Cover for SR200, SR300 Pump	1
13	89021301	Motor SR100 (220V /50Hz)	1	01031002	Fan Cover for SR100, SR150 Pump	1	
	89021302	Motor SR150 (220V /50Hz)	1	01031008	Fan Cover for SR200, SR300 Pump	1	
	89021303	Motor SR200 (220V /50Hz)	1	01031009	Fan Cover for SR100, SR150 Pump	1	

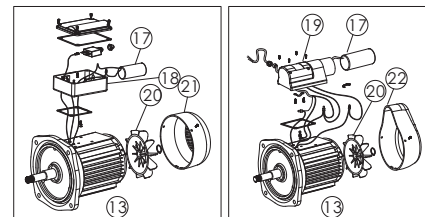
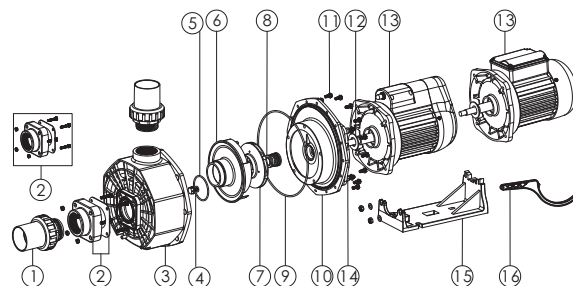

Salt Chlorinator Operation(1)

Working Principle

The chlorinator uses electrolysis to break down the salt (NaCl) in the swimming pool to form Chlorine (Cl₂). The control unit of the chlorinator can regulate the chlorine production by altering the electric current flow through the titanium electrode in the cell housing. Chlorine is an effective sanitizing agent which is commonly used in swimming pools, it can inhibit the growth of bacteria and fungi.

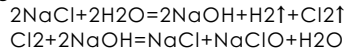

Product Features

- Convenience and the constant delivery of pure chlorine-based sanitizer.
- No more artificial chemical cleaning agent which could cause skin and eye irritation. You just need to add natural salt in the pool.
- The salt in the water is so little you do not taste or smell the salt.
- The electrode is made of titanium, which is durable and resistant to corrosion.
- Easy to install and operate.
- The water does not have the heavy smell of chlorine because chlorine is not directly added to the pool.

Product Picture



Salt chlorinator control box Electrolytic cell 1.5"/2" universal union Cables Screw and fuse Manual



Product Dimension

Control Box: 360 x 220 x 135 mm
 Electrolytic cell: 380 x 118 x 130 mm

Working Condition

Environment Temperature: 0 degree Celsius to 50 degree Celsius
 Installation Area must be with good ventilation
 Keep away from other heat source

Chlorine Level Calculation

Required Chlorine Production Rate (g/hr) =

$$\frac{\text{Pool volume (litre)} \times \text{Standard Chlorine (g/litre)}}{\text{Turnover Rate (hr)}}$$

Standard Chlorine Level not less than 2mg/litre = 0.002g/litre

Example :

Pool Volume: 65m³ = 65,000litre

Turnover Rate: 4 Hour

Required Chlorine Production Rate (g/hr) =

$$\frac{65,000 \text{ litre} \times 0.002 \text{ g/litre}}{4 \text{ Hours}} = 32.5 \text{ g/hr}$$

Salt Chlorinator Operation(2)

Product Specification

SSC-TLT Series

(Chlorinator with underwater light, transformer and time switch)

Model	Salt chlorinator voltage input/ freq	Rating (salt chlorinator and underwater light transformer)	Cell Output	Fiberglass Pool (Litre)	Concrete Pool (Litre)
SSC15-TLT	220 ~ 250VAC 50/60Hz	100VA +100VA (underwater light)	15g/hr	50000	45000
	100 ~ 120VAC 50/60Hz				
SSC25-TLT	220 ~ 250VAC 50/60Hz	100VA +160VA (underwater light)	25g/hr	75000	70000
	100 ~ 120VAC 50/60Hz				

SSC-T Series

(Chlorinator with time switch)

Model	Salt chlorinator voltage input/ freq	Rating (salt chlorinator and underwater light transformer)	Cell Output	Fiberglass Pool (Litre)	Concrete Pool (Litre)
SSC15-T	220 ~ 250VAC 50/60Hz	100VA	15g/hr	50000	45000
	100 ~ 120VAC 50/60Hz				
SSC25-T	220 ~ 250VAC 50/60Hz	160VA	25g/hr	75000	70000
	100 ~ 120VAC 50/60Hz				
SSC50-T	220 ~ 250VAC 50/60Hz	300VA	45g/hr	120000	110000
	100 ~ 120VAC 50/60Hz				

SSC-E Series

(Basic Salt Chlorinator)

Model	Salt chlorinator voltage input/ freq	Rating (salt chlorinator and underwater light transformer)	Cell Output	Fiberglass Pool (Litre)	Concrete Pool (Litre)
SSC15-E	220 ~ 250VAC 50/60Hz	100VA	15g/hr	50000	45000
	100 ~ 120VAC 50/60Hz				
SSC25-E	220 ~ 250VAC 50/60Hz	160VA	25g/hr	75000	70000
	100 ~ 120VAC 50/60Hz				
SSC50-E	220 ~ 250VAC 50/60Hz	300VA	45g/hr	120000	110000
	100 ~ 120VAC 50/60Hz				

Installation Guide

Control Unit

- 1) Select a convenient well-ventilated location within one meter of filter equipment.
- 2) Mount the control unit vertically onto a post or wall 1.5 meters above ground level. (Australian Standards requires that the electric control unit shall not be located within 3 meters of the pool water.)
- 3) Plug Power supply into a suitable weatherproof outlet .
- 4) Plug pump into the power outlet of the Power Supply Unit. (applicable for SSC-TLT Series only)
- 5) The Unit must be kept away from acid and other chemical storage areas. Acid and chemical vapors will corrode the electronics inside the Unit.
- 6) It must also be kept away from heat sources.

Caution:

The control unit can connect to one pump and one underwater light only (SSC-TLT Series Only)
The current loading of the pumped connected must not exceed 8 Amp. (SSC-TLT Series Only)

Electrolytic cell and Electrode

- 1) The cell must be installed horizontally
- 2) Connect the water inlet and outlet to the Cell Unit. The water flow direction must be as indicated on the Cell.
- 3) To avoid lost of chlorine, the Cell should be installed at the end of the filtration system, right before the pool water return.



Salt Chlorinator Operation(3)

SSC-E SERIES INSTALLATION

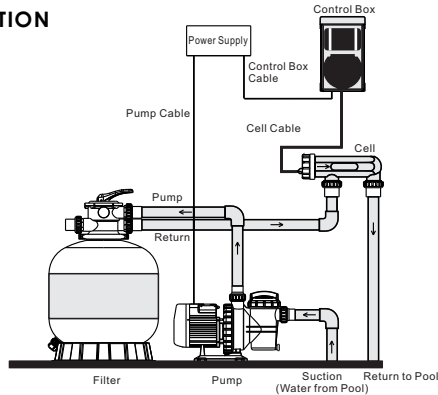

SSC-T & SSC-TLT SERIES INSTALLATION

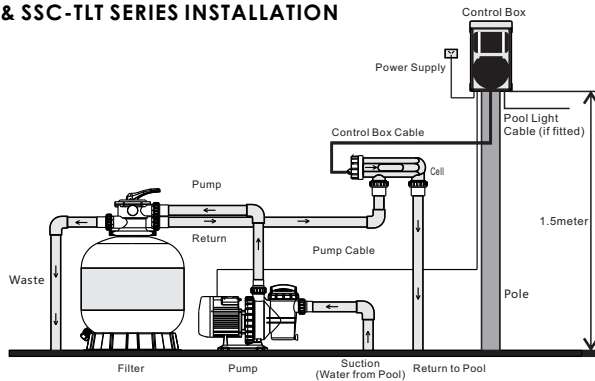

1) Two self-tapping screws and wall plugs have been provided for fast and simple installation. Simply cut out Template provided for the location of drill entry points. Use a 8mm masonry drill when fitting control unit to a brick or concrete wall. When mounting to a post drill pilot holes and fit screws provided. Once screws are in position simply hang the chlorinator via the bracket on back of Control Box.

2) Glue the salt cell horizontally on the pool return pipe, allow 24 hour curing of the pipe glue.

3) Used the provided cable to connect the control unit and the salt cell together,

The single black plug should be connected to the control unit.

The yellow wire shall be connected to the gas sensor of the Cell.

The black wires shall be connected to the electrodes; the connectors may be fitted either way.

Salt Chlorinator Operation(4)

Operation Overview

- 1) Power input: 220-240VAC, 50/60Hz
- 2) Recommended pool salt lever: 4000PPM or above (no less than 40kg of pure salt dissolved in 10,000 liter of pool water)
 - › Run chlorinator at the Salt Levels stated within this document and on the product to ensure optimum sanitizer output and cell life.
 - › Operating this device at low salt levels will damage the cell and reduce its life.
 - › The control unit displays a RED indicator when the salt level is low.
 - › If no action is taken to rectify the salt level, damage to the cell may result which will not be covered under warranty.
- 3) During extreme hot weather conditions or high bather load, the pool water need to be super-chlorinated using granulated or liquid chlorine or increase the running time of the chlorinator.
- 4) Always turn down the system control to zero before adding salt, once the salt is completely dissolved, return to the set position.
- 5) The aluminum casing at the back of the Control Unit acts as a heat sink, do not touch it with bare hands.

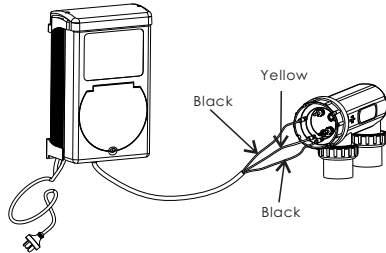

Control Panel

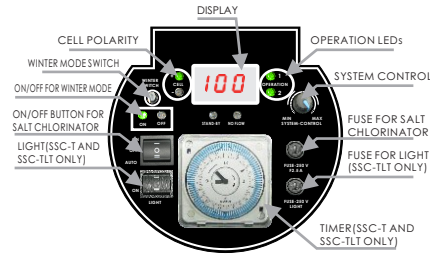

OPERATION LEDS

Fuse: Used to protect the electronic components inside the control unit.
Operation LED: There are three status of the operation LED, for example

Status1: Normal Operation

(Green) ● 1
Operation

(Green) ● 2

Status2: Low salt level/ Deposition on the electrode/ Low water temperature

(Green) ● 1
Operation

(Red) ● 2

Status3: Extremely low salt level/ Serious deposition on the electrode/ Extremely low water temperature

(Red) ● 1
Operation

(Red) ● 2

Salt Chlorinator Operation(5)

SALT CHLORINATOR On/Off/Auto: ON/Off Switch. In Auto mode, the chlorinate is operated by the timer setting
Light On/Off: Switch for underwater light connected to the control unit (For certain model)

System Control: Adjust the chlorine product of the chlorinator, for example, for the control unit turned on for 8 hours

Set at 100% - The salt cell operated at 8 hours

Set at 50% - The salt cell operated at 4 hours

Set at 25% - The salt cell operated at 2 hours

Display: Show the percentage of the chlorine production

Winter Mode Switch and On/ Off LED: Turn on to change the chlorine production at 85% .

Cell Polarity LED: Show the polarity of the electrodes; the polarity of the electrode will shifted every 8 hrs of operation, so as to clean the deposition on the electrode.

Timer: Used to set the program to turn on and off the control unit automatically. (SSC-T AND SSC-TLT ONLY)

Stand-By LED: Turn on when chlorinate is in stand-by mode, When the chlorinator is turn on, the standby LED will go off after 35 sec.

No Flow LED: Turn on if there is no water flow, if there is no water flow, the pump and salt chlorinator will stop automatically.

On/Off/Auto:

Light On/Off:

System Control:



TIMER OPERATION for SSC-TLT & SSC-T Series Only

- 1) Turn the outer clock face until the time of the day is aligned with the clock at the center of the timer
- 2) The 24-hour dial has 15 minutes division. The timer can be programmed by pushing the captive trippers to the outer ring position for the entire period that the load is to be turn ON.
- 3) The timer clock will rotate with time; the chlorinator will be turned on automatically if its captive tripper is pushed outward.



Maintenance and Troubleshooting

Salt Chlorinators are a valuable piece of pool sanitizing equipment and must be cared for to get the best performance and life span from it.

- 1) Keep the water chemical balance
- 2) Good operation environment
- 3) Regular check of the
- 4) During the chlorination process a white powder Calcium scale may naturally build up on the titanium plates in the cell. Regular monitor of the cell to prevent excessive scale build up. Excessive scale build up will cause damage to your cell, and dramatically reduce its efficiency and lifespan.
- 5) Avoid any insect from entering the control box, it may damage the electrical component inside.
- 6) Regular monitor of the filter and pump

Salt Chlorinator Operation(6)

Troubleshooting guide

1. Low/no chlorine production	How to handle
Check the electrical plug / control box / pump power	Connect the power properly
Setting system is too low	Turn the system control to maximum
Automatically stopped by the timer setting	Adjust the timer setting
Blown fuse	Cut the power and replace the fuse
excessive scale build up on the cell	Switch off the salt chlorinator and clean the salt cell by professional serviceman
Filter Backwashing	Once the backwash is complete, turn the filter back to normal filtration
The gas sensor is not connected	Connect the gas sensor according to this manual
Pump malfunction	Stop the filtration system and repair the pump
Water temperature too low	Turn on the winter switch
Salt lever too low	Add salt to the pool
pH valve too high	Check the water pH valve and keep it around 7.0-7.6
2. No flow	
Pump malfunction	Stop the filtration system and repair the pump
Filter Backwashing	Once the backwash is complete, turn the filter back to normal filtration
The gas sensor is not connected	Connect the gas sensor according to this manual
3. No display	
Setting system is too low	Turn the system control to maximum



