

# Instruction on Installation of EM2817V Series Main Drain

Models: EM2817V(A1) EM2817V(A2)

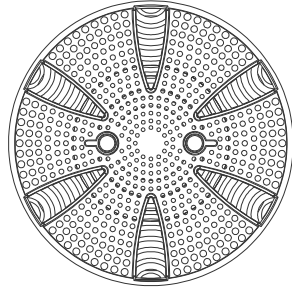

## Notices on Installing Glass Fiber Pool

All EM2817V Series suction machines have been tested and are compliance with the standard AS/NZS 1926.3.2010.

Emaux Company suggests that all installation personnel are familiar with the standard AS/NZS 1926.3.2010 before the installation.

The installation personnel has the responsibility to ensure that the maximum flow rate doesn't exceed the standard .

All EM2817V Series suction machines should be fixed on the pool wall permanently, so as to prevent the displacement in the absence of tools.

Provide all fixing screws needed in the installation of EM2817V Series suction machines.

Any revising to the device as well as its installation will cause the invalidity of conformity certification and warranty; in addition , it will affect the safety of this device .

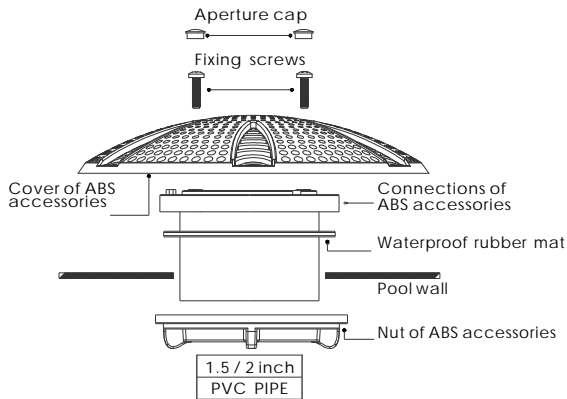

Product Description	Aperture cap	Fixing screws	ABS accessories	Waterproof rubber mat
Qty	2	2	3	1

Models: EM2817C(A1) EM2817C(A2) EM2817C(A3) EM2817C(A4)  
 EM2817C(A5) EM2817C(A6)  
 EM2817C(E1) EM2817C(E2) EM2817C(E3) EM2817C(E4)

### Notice on the Installation of Concrete

All EM2817C Series suction machines have been tested and are compliance with the standard AS/NZS 1926.3.2010.

Emaux Company suggests that all installation personnel are familiar with the standard AS/NZS 1926.3.2010 before the installation.

The installation personnel has the responsibility to ensure that the maximum flow rate doesn't exceed the standard .

All EM2817C Series suction machines should be fixed on the pool wall permanently, so as to prevent the displacement in the absence of tools.

Provide all fixing screws needed in the installation of EM2817C Series suction machines.

Any revising to the device as well as its installation will cause the invalidity of conformity certification and warranty; in addition , it will affect the safety of this device .

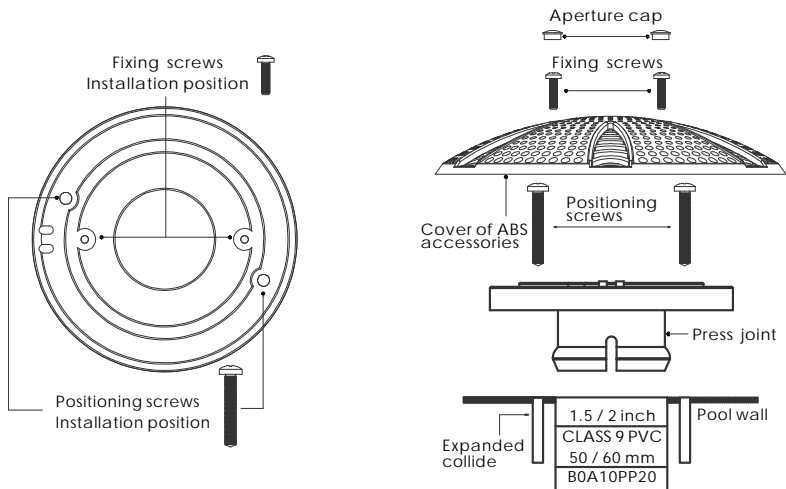

Product Description	Aperture cap	Fixing screws	Positioning screws	Expanded collide	ABS accessories	Press joint
Qty	2	2	2	2	1	1