

2.0 " Clamp Type Multiport Valve

PARTS OF VALVE

Item	Part No.	Description	Qty
1	430135070	Handle (Red)	1
2	03018008	Pin for Handle	1
3	01181027	Washer for Handle	1
4	01181028	Defend Lock	1
5	01020009	2.0" Lid	1
6	01181002	Washer for Spring	1
7	02011022	O-Ring for Valve Rotor	2
8	03014014	Spring for Valve	1
9	89280805	2.0" Valve Rotor with Spider Gasket	1
10	02010003	O-Ring for Lid	1
11	E190213	2.0" Body with Diffuser	1
12	89280120	Drain Plug Fitting with O-ring	1
13	89021307	Drain Plug with O-Ring	1
14	06011029	Oil Pressure Gauge with O-Ring (40Psi)	1
14	117043348	Pressure Gauge with O-Ring (100Psi)	1
15	02020016	O-Ring	6
16	01013031	2.0" Connector (Black)	3
16	01051033	2.0" Connector (White)	3
17	01171154	2.0" Union (A/E)	3
18	01013032	2.0" Union Nut (Black)	3
18	01051032	2.0" Union Nut (White)	3
19	430200944	Sight Glass with O-Ring	1
20	02011005	O-Ring for Diffuser	1

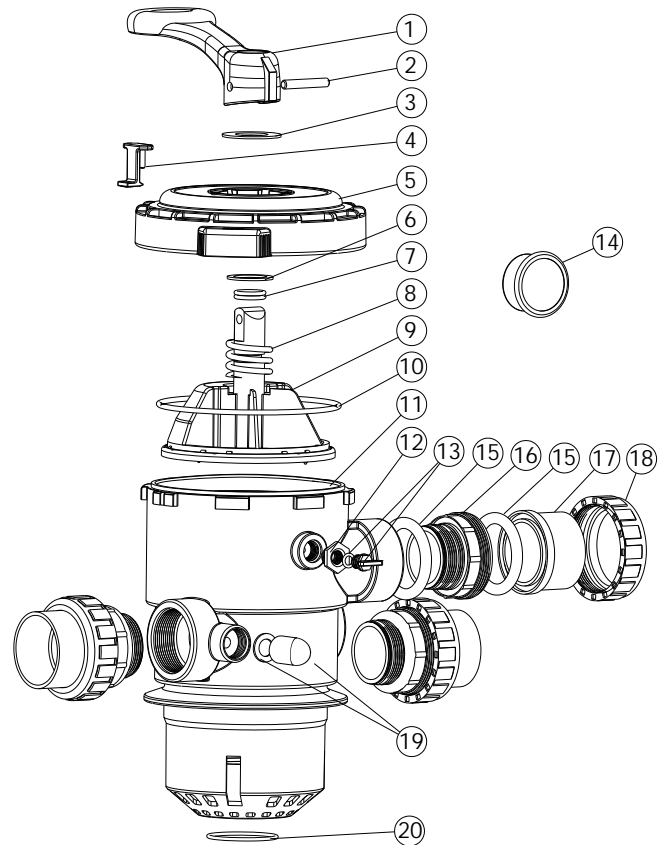

NOTE:

Item 1-13, 19, 20 for Valve only (88281506).

Item 1-20 for Valve (88281551).

WARNING



TURN PUMP OFF BEFORE CHANGING VALVE POSITION.



THIS FILTER OPERATES UNDER HIGH PRESSURE. WHEN ANY PART OF THE CIRCULATING SYSTEM (e.g., CLAMP, PUMP, FILTER, VALVES, ETC.) IS SERVICED, AIR CAN ENTER THE SYSTEM AND BECOME PRESSURIZED. PRESSURIZED AIR CAN CAUSE THE LID OR VALVE TO BE BLOWN OFF WHICH CAN RESULT IN SEVERE INJURY, DEATH, OR PROPERTY DAMAGE



TO PREVENT DAMAGE TO THE PUMP AND FOR PROPER OPERATION OF THE SYSTEM, CLEAN PUMP STRAINER AND SKIMMER BASKETS REGULARLY.

FUNCTIONS OF VALVE POSITIONS

Valve Position	Function
FILTER	Normal Filtration
BACKWASH	Cleaning Filter by reversing the flow
RINSE	Used after backwash to flush dirt from valve
WASTE	By-passes filter, used for vacuuming to waste or lowering water level
RECIRCULATE	By-passes filter for circulating water to pool
CLOSED	Shuts off all flow to filter or pool

FILTER

WASTE

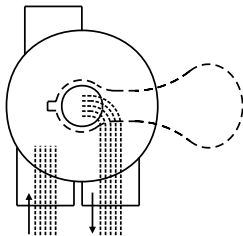

IN FLOW OUT FLOW

WASTE

WASTE

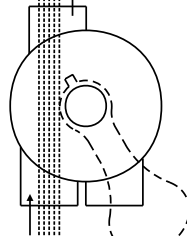

IN FLOW OUT FLOW

CLOSED

WASTE

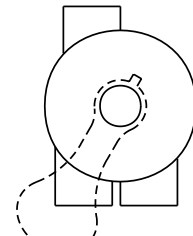

IN FLOW OUT FLOW

BACKWASH

WASTE

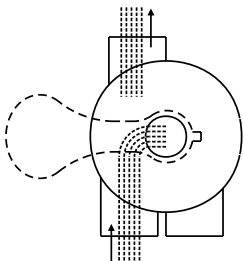

IN FLOW OUT FLOW

RINSE

WASTE

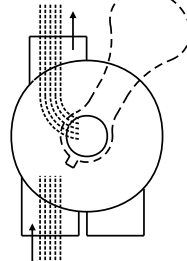

IN FLOW OUT FLOW

RECIRCULATE

WASTE

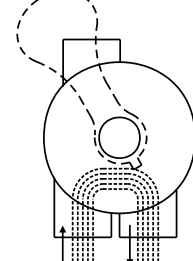

IN FLOW OUT FLOW

GENERAL

- 1) Pipe tap boss provided for optional influent pressure gauge.
- 2) SERVICING VALVE(Stop pump,close gate valve in suction&discharge before proceeding):
 - a) Set handle in filter position.
 - b) Remove cover screws.
 - c) Lift cover and key assembly out.

TO ASSEMBLE:

- d) Place valve key so that wedge opening is at TOP port (handle in Filter psn.). Flat edge of cover screw lug should align with flat edge of body screw lug.
- e) Position cover O'Ring.
- f) Secure assembly to body with cover screws. Tighten cover screws evenly and alternately. Do not over-tighten.