

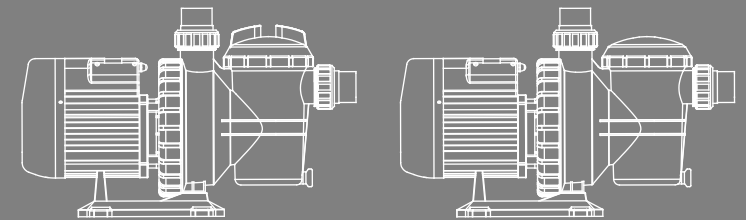

# SC & SCUS SERIES CENTRIFUGAL PUMP

Installation and Operation Manual



## USER MANUAL

EMAUX WATER TECHNOLOGY CO., LTD  
ADDRESS FLAT A-D, 20/F., KAI BO 22, 22 WING KIN ROAD,  
KWAI CHUNG, HONG KONG  
PHONE +852 2832 9880

💧 STRIVE FOR CLEAR WATER

[www.emauxgroup.com](http://www.emauxgroup.com)



EMPU21070141

# TABLE OF CONTENT

PAGE	
2	..... WARNINGS AND SAFETY INSTRUCTIONS
4	..... 1.SC & SCUS SERIES CENTRIFUGAL PUMP OVERVIEW
4	..... 2.PRODUCT INFORMATION
6	..... 3.IMPORTANT SAFETY INSTRUCTIONS
6	..... 4.INSTALLATION
9	..... 5.START UP
10	..... 6. ROUTINE MAINTENANCE
11	..... 7. WINTERIZING
12	..... 8. TROUBLE SHOOTING
13	..... 9. REPLACEMENT PARTS
16	..... 10. TERMS OF THE WARRANTY

## WARNINGS AND SAFETY INSTRUCTIONS GENERAL WARNING

This instruction contain general caution information for use in Pool and SPA pump installation application. Specified Pump model function should be refer to particular manual. Components such as the filtration system, pumps and heater must be positioned so as to prevent their being used as means of access to the pool by young children.



### RISK OF ELECTRICAL SHOCK

This appliance should be installed by qualified electrical personnel in accordance with National Electrical Code and all applicable local codes and ordinances. Hazardous voltage can shock, burn, and cause death or serious property damage. DO NOT use an extension cord to connect unit to electric supply to reduce the risk of electric shock.

1. The pump should be permanently connected to an individual circuit breaker.
2. Pump must be connected to a residual current device (RCD) having a rated residual operating current not exceeding 30 mA or receptacle with ground fault circuit interrupt (GCFI).
3. Electrical grounding must be connected before connecting to electrical power. Failure to ground all electrical equipment can cause serious or fatal electrical shock hazard.
4. Bonding: Use at least #8 AWG (#6 AWG for Canada) a solid copper conductor, run a continuous wire from external bonding lug (if available) to the pressure wire connector provided on the electrical equipment and to all metal parts of swimming pool, spa, or hot tub, and metal piping (except gas piping), and conduit within 1.5 m (5 ft) of inside walls of swimming pool, spa, or hot tub.
5. Never open the inside of the drive motor enclosure. There is a capacitor bank that holds a mains supply voltage charge even when there is no power to the unit. The voltage should be referred to the individual pump operation voltage.
6. The pump is capable of high flow rates; use caution when installing and programming to limit pumps performance only.
7. Switch OFF pump power before servicing and disconnecting the main circuit to the pump.
8. Never change the filter control valve position while the pump is running.

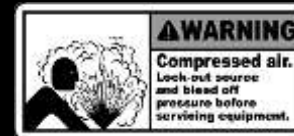

### COMPRESS AIR HAZARDOUS

This system enclosed pre-filter / filter and become pressurized. Pressurized air can cause the Lid to separate which can result in serious injury or death.

### STAND CLEAR OF PUMP DURING START-UP

Pool and spa circulation systems operate under high pressure. When any part of the circulating system (i.e. lock ring, pump, filter, valves, etc.) is serviced, air can enter the system and become pressurized. Filter tank Lid and pre-filter cover must be properly secured to prevent violent separation. Place pre-filter / filter air relief valve in the open position and wait for all pressure in the system to be relieved before remove the lib to access the basket for cleaning.



### HYPERTHERMIA

SPA water temperature excess 38°C (104°F) may be injurious to health. Measure water temperature before entering SPA. Hyperthermia occurs when the internal temperature of the body reaches a level several degrees above the normal body temperature of 98.6 °F (37 °C). The symptoms of hyperthermia

include drowsiness, lethargy, and an increase in the internal temperature of the body.



## SUCTION ENTRAPMENT HAZARD

This pump produces high levels of suction and creates a strong vacuum at the main drain at the bottom of your pool and spa. This suction is so strong that it can trap adults or children under water if they come in close proximity to a pool or spa drain or a loose or broken drain cover or grate.

The Virginia Graeme Baker (VGB) Pool and Spa Safety Act creates new requirements for owners and operators of commercial swimming Pools and spas.

Commercial pools or spas constructed on or after December 19, 2008, shall utilize:

1. A multiple main drain system without isolation capability with suction outlet covers that meet ASME/ANSI A112.19.8a Suction Fittings for Use in Swimming Pools, Wading Pools, Spas, and Hot Tubs and either:
  - 1.1 A safety vacuum release system (SVRS) meeting ASME/ANSI A112.19.17 Manufactured Safety Vacuum Release systems (SVRS)  
For Residential and Commercial Swimming Pool, Spa, Hot Tub, and Wading Pool Suction Systems and/or ASTM F2387 Standard Specification for Manufactured Safety Vacuum Release Systems (SVRS) for Swimming pools, Spas and Hot Tubs or
  - 1.2 A properly designed and tested suction-limiting vent system or
  - 1.3 An automatic pump shut-off system.

Commercial pools and spas constructed prior to December 19, 2008, with a single submerged suction outlet shall use a suction outlet cover that meets ASME/ANSI A112.19.8a and either:

1. A SVRS meeting ASME/ANSI A112.19.17 and/or ASTM F2387, or
2. A properly designed and tested suction-limiting vent system, or
3. An automatic pump shut-off system, or
4. Disabled submerged outlets, or
5. Suction outlets shall be reconfigured into return inlets.

There are five types of suction entrapment according to The Virginia Graeme Baker (VGB) Pool and Spa Safety Act

- 1 Body Entrapment a section of the torso becomes entrapped
- 2 Limb Entrapment an arm or leg is caught by or pulled into an open drainpipe
- 3 Hair Entrapment or entanglement hair is pulled into and/or wrapped around the grate of the drain cover
- 4 Mechanical Entrapment the bather's jewelry or clothing gets caught in the drain or the grate
- 5 Evisceration the victim's buttocks come into contact with the pool suction outlet and he or she is disemboweled



### TO REDUCE ENTRAPMENT HAZARD RISK

Two function suction outlets per pump must be installed to prevent entrapment. The minimum separate of suction on the same plate must be at least point to point measurement 1 meter (3ft) apart. It is used to avoid "dual blockage" by bather.

If suction is found damage, broken, cracked, missing or not securely attached during regular checking, shunt down the pool and replace it immediately.

A vacuum release or vent system is recommended to install for suction entrapment release.



**WARNING:**

## 1. SC & SCUS SERIES CENTRIFUGAL PUMP OVERVIEW

It is a low power, low noise and easy to maintenance self-priming pump for small residential in ground pool installation. SC and SCUS series Pre-filter with transparent Lid cover easy to observe the basket need to be clean or not.

IPX5 aluminum motor enclosure design is good for outdoor deployment and heat dissipation.

There is built in thermal protection to protect the motor when fault operation cause motor over heat.

SCUS is a 115V/230V 60Hz dual voltage pump which need a 3 phase electric power supply for 230Vac operation.

## 2. PRODUCT INFORMATION

Model	Input Voltage	Input (kW)	Current (AMP)	Noise (dB)	Head(m)					
					4	6	8	10	12	14
					FlowRate(m <sup>3</sup> /h)					
SC050	220V 50/60Hz	0.51	2.5	60	12	6.8	-	-	-	-
SC075		0.75	3.5	68	16.4	13.8	9	-	-	-
SC100		0.97	4.7	70	19	17	14	10	-	-
SC150		1.30	5.9	70	22	20	17.2	14	-	-
SC200		1.71	8.2	73	26	23.2	21	18	-	-
SCUS100	115/230V 60Hz	0.97	8.4/4.2	70	17	15	12	7	-	-
SCUS150		1.40	12.4/6.2	70	-	20	18	15	11.8	5
SCUS200		1.80	16.0/8.0	73	-	22	20.8	18.6	16	13

### DIMENSIONS

SC

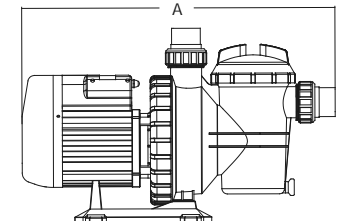
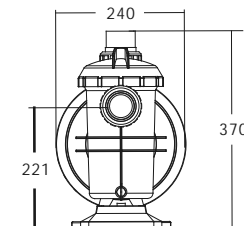

SCUS

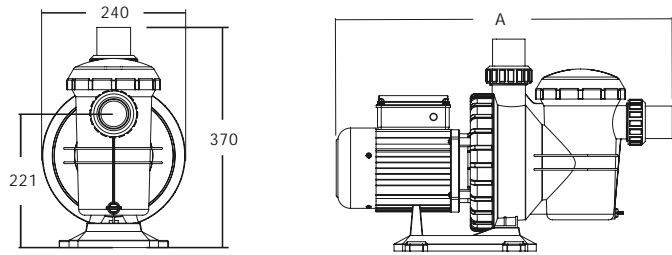

Code 220V 50Hz	Code 220V 60Hz	Code 230V/115V 60Hz	Model	Connection Size	Horsepower	Weight (kg)	Capacitance 220V	Capacitance 110V
88021703	88021803	/	Sc050	1.5" / 50mm	0.5hp	10.4	14µF	40µF
88021704	88021804	/	SC075	1.5" / 50mm	0.75hp	12.1	20µF	60µF
88021705	88021805	/	SC100	1.5" / 50mm	1.0hp	13.4	25µF	90µF
88021707	88021807	/	SC150	1.5" / 50mm	1.5hp	14.9	25µF	90µF
88021708	88021808	/	SC200	1.5" / 50mm	2.0hp	15.4	30µF	90µF
/	/	88020605	SCUS100	1.5" / 50mm	1.0hp	15	/	/
/	/	88020607	SCUS150	1.5" / 50mm	1.5hp	16	/	/
/	/	88020608	SCUS200	1.5" / 50mm	2.0hp	17.5	/	/

### PERFORMANCE CURVE

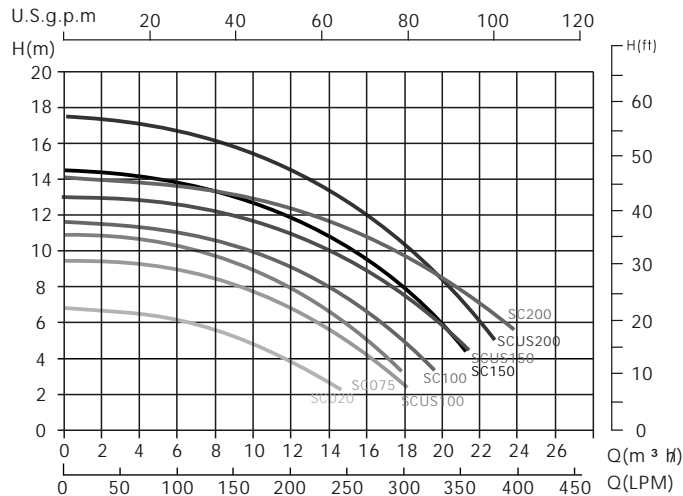

Remark: The performance curve above is for 50Hz models

## 3. IMPORTANT SAFETY INSTRUCTIONS

 **WARNING:** The user guide you are holding includes essential information on the safety measures to be implemented for installation and start-up. Therefore, the installer as well as the user must read the instructions before beginning installation and start-up. Keep this manual for future reference.

The pump should be installed according to your local electrical installation ordinances and regulations. Only qualified, licensed personnel should install the pump and the wiring.

This appliance cannot be used by persons (including children) with reduced physical, sensory or mental capabilities or lack of experience and knowledge unless they have been given supervision or instruction concerning use of the appliance in a safe way and understand the hazards involved. Children must not play with the appliance.

This appliance can be used by children aged from 8 years and above and persons with reduced physical, sensory or mental capabilities or lack of experience and knowledge if they have been given supervision or instruction concerning use of the appliance in a safe way and understand the hazards involved. Children shall not play with the appliance. Cleaning and user maintenance shall not be made by children without supervision.

## 4. INSTALLATION

### 4.1 PIPING

1. Install the pump as close to the pool as possible, preferably in a dry, well ventilated area away from direct sunlight. Protect the pump from excessive moisture.
2. Place the pump as close to the water source as possible, so that the suction pipe is short, straight and direct to reduce the friction loss. Don't install the pump at more than 10 ft (3 meters) of geometrical height from water level.
3. Before installing the pump, make sure that the surface is solid, elevated, rigid and vibration free.
4. Secure the pump to the base with screws or bolts to limit the vibration and the stress on the pipe or the joints.
5. Leave enough space for gate valves in suction and discharge piping, if required.
6. Ensure there is enough clearance for pre-filter basket & Lid open and motor ventilation.
7. Connect the suction and discharge pipe to the outlet and inlet of the swimming pool.
8. Make sure that floor drainage is adequate to prevent flooding.
9. Make sure that the pump and piping are accessible for servicing.

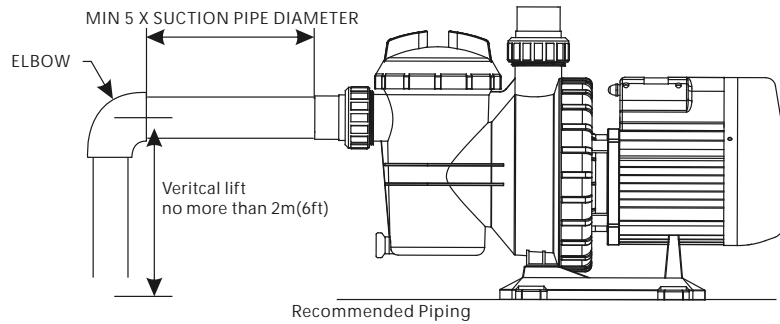

Note: The pump suction and discharge connections are mounded in thread stops, DO NOT try to screw the pipe beyond these stops.  
The two sets of 1.5" or 2" (refer to individual product connection) union adaptor are universal design for metric and imperial for PVC pipe connection.



## 4.2 ELECTRICAL WIRING



This power pump demand licensed or certified electrician or qualified pool installer to ensure there is adequate protection between the pump motor and mains power supply according to individual countries safety code.

The pump has power cord with plug attached on the plug, plug it to a power socket with circuit breaker to isolate the motor from the mains power for over load protection. The circuit breaker rating should refer to the electrical specification of individual pump working voltage and power.  
The power has to be with a Residual Current Device (RCD) or Ground Fault Circuit Interrupt (GFCI) having a rated residual operating current not exceeding 30mA.



If the RCD / GFCI device trips, it means there is fault on the power line or motor. Do not use this pump. Disconnect the pump and have the problem corrected by a qualified service representative before using. Press the reset button to reset the RDC / GFCI devices after fixed. It will keeps the circuit shut off and will not reset if the power

line problem is not fixed.

It is recommend to test the RCD / GFCI at least once a month.

Pumps should be shipped with Power cord with plug for corresponding countries. If there is not power cord attached to the pump, it is necessary to follow the local electricity power line color code to connect the power according to the wiring for individual pump diagram.

## 4.3 WIRING BOX DIAGRAM

SCUS100, SDUS150 and SCUS200 is 115/230V dual voltage operation pump for United State market. 3 phase electricity power source is needed when 230V is connected. 115V or 230Vac have to connect L1 line to terminal L1 and L2 line to L2 terminal according to the wiring diagram.

SCUS100, SCUS150 and SCUS200 (230Vac)



Ground on motor metal case

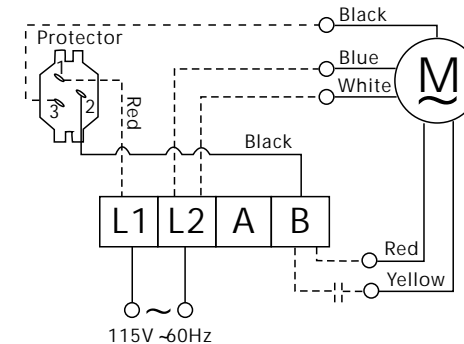

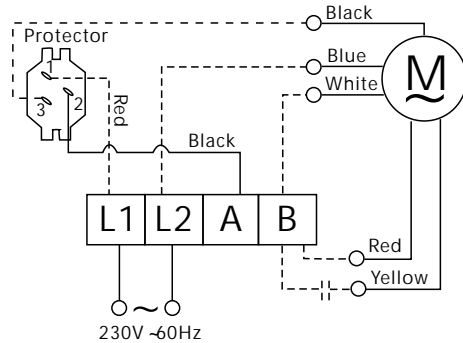
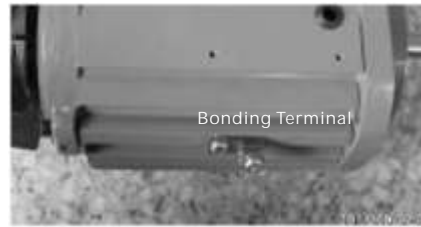

Bonding Instructions – Permanently wired units will need to include instructions for connecting the solid copper, equipotential bonding conductor. For SCUS200, SCUS100, and SCUS150 with ETL Mark for the United States, the size of the bonding conductor should be No.8 AWG. For Canada the size of the bonding conductor should be No. 6 AWG. Bonding Nut location is as photo.



## 5. START UP



**WARNING:**

- 1 .Verify the pump shaft turn freely.
- 2 .Check the mains voltage, current and frequency are accordingly to the name plate.
- 3 .Never run pump dry! Running pump dry may cause damage to the mechanical seal causing leakage and flooding. Fill the pre-filter with water before starting motor.
- 4 .Before removing the pre-filter Lid, STOP PUMP, CLOSE GATE VALVES in suction and discharge pipes.
- 5 .Always STOP THE PUMP before when RELEASE ALL PRESSURE from the pump and the piping system before proceeding.
- 6 .Never tighten or loosen screw while the pump is in operation.
- 7 .The suction pipe and the suction inlet in the pool must be free from obstruction.

## Tighten/untighten the pump Lid by hand only.



**WARNING:**

Before start-up, the alignment of the pump should be checked. The tubing should be inspected to ensure that they are properly fitted and tightened and that they do not exert pressure or tension on the pump's suction or discharge connection. The pump should never be operated.

1. Clear all piping of construction debris and verify that the piping has passed a proper pressure test.
2. Check the filter and other equipment for proper installation, verifying all clamps and connections are properly installed as per the manufacturer's instructions.
3. Open any shut off valves on the suction and discharge lines.
4. Open the filter pressure relief valve and release all pressure from the system.
5. If the pump is located below the water level of the pool, opening the pressure relief valve will fill the pump with water.
6. If the pump is located above the pool water level, remove the Lid from the pre-filter and fill with water before starting the pump.
7. Check to see that the Lid O-ring and seat areas are clean and lubricated. Debris in the sealing area can cause air to leak into the system and make it difficult to prime the pump.
8. Close/tighten the Lid to make an airtight seal.
9. Turn on the pump.
10. If the pump does not prime within 15 minutes. Ensure all instructions to this point have been followed. Stop the pump! Check for suction leaks and repeat steps (1) through (8).

## 6. ROUTINE MAINTENANCE

The only routine maintenance needed is the inspection and cleaning of the pre-filter basket. Debris or trash collected in the basket will choke off the water flow through the pump. Follow the instructions below in order to clean the pre-filter basket:

1. Turn off the pump, close the gate valve in suction and discharge, and release all pressure from the system before proceeding.
2. For SC pump series, turn the transparent Lid cover follow the arrow on the Lid cover by opening key provided to release and lock the Lid ring. For SCUS pump series, place the key for Lid around the transparent Lid cover, hold the two handles and turn anti clockwise to release the Lid.
3. Remove the pre-filter basket and cleaning. Make sure all the holes in the basket are clear, flush the basket with water and replace it in the trap with large opening at the pipe connection port(between ribs provided). If the basket is replaced back wards, the cover will not fit on the trap body.

4. Clean and inspect the Lid's O-ring ring; reinstall on the Lid cover.
5. Clean the ring groove on the pre-filter body and replace the Lid. To help keep the Lid from sticking, tighten it by hand only.
6. Fill up the filter body with water and Prime the pump.

SC Series



SCUS Series



Basket opening face to suction inlet



## 7. WINTERIZING

If the air temperature drops below 0°C (35°F), the water in the system can freeze and cause damage. Freezing damage is not warrantable.

To prevent freezing damage follow the procedures listed below:

- 1 Shut off electrical power for the pump at the house circuit breaker.
- 2 Drain the water out of the pump case by removing the two drain plugs from the case.
- 3 Store the plugs in the pump basket.
- 4 Cover the motor to protect it from severe rain, snow and ice.
- 5 If it is possible, store the pump in a dry location during this time.
- 6 Do not wrap the motor in plastic. It will cause condensation and rust on the inside of the motor.

## 8. TROUBLE SHOOTING

Problem description	Possible causes
Motor does not start	<ol style="list-style-type: none"> <li>1 .Disconnect switch or circuit breaker in off position</li> <li>2 Fuses blown or thermal overload open</li> <li>3 Locked motor shaft</li> <li>4 .Motor windings burned out</li> <li>5 .Defective starting switch inside single phase motor</li> <li>6. Disconnected or defective wiring</li> <li>7 Low voltage</li> </ol>
Pump does not reach full speed	<ol style="list-style-type: none"> <li>1. Low voltage</li> <li>2. Pump connected to the wrong voltage</li> </ol>
Motor overheats (protector trips)	<ol style="list-style-type: none"> <li>1. Low voltage</li> <li>2. Motor windings connected to the wrong voltage on dual voltage model</li> <li>3. Inadequate ventilation</li> </ol>
Pump delivers no water	<ol style="list-style-type: none"> <li>1 Pump is not primed</li> <li>2 .Closed valve in suction or discharge line</li> <li>3 Leakage or air into suction system</li> <li>4 .Impeller clogged</li> </ol>
Leakage of water at the shaft	<ol style="list-style-type: none"> <li>1 Shaft seal requires replacement</li> </ol>
Low pump capacity	<ol style="list-style-type: none"> <li>1. Valve in the suction or discharge line partly closed</li> <li>2. Suction or discharge line partly plugged</li> <li>3. Suction or discharge line too small</li> <li>4. Plugged basket in skimmer or hair and lint pre-filter</li> <li>5. Dirty sand filter</li> <li>6. Impeller clogged</li> </ol>
High pump pressure	<ol style="list-style-type: none"> <li>1. Discharge vale or inlet fittings closed too much</li> <li>2. Return lines too small</li> <li>3. Dirty filters</li> </ol>
Noisy pump and motor	<ol style="list-style-type: none"> <li>1 Plugged basket in skinner or hair in lint pre-filter</li> <li>2 .Worn motor bearings</li> <li>3 .Valve in suction line partly closed</li> <li>4 .Suction line partly plugged</li> <li>5 .Vacuum hose plugged or too small</li> <li>6 .Pump not supported properly</li> </ol>
Air bubbles at inlet fittings	<ol style="list-style-type: none"> <li>1 Leakage of air into the suction line in connections or valve stem</li> <li>2 .Cover gasket of hair and lint pre-filter needs cleaning</li> <li>3 Low water level in the pool</li> </ol>

Note: If the above recommendations of this manual do not solve your particular problem(s), please contact your local service agent for further assistance.

## 9. REPLACEMENT PARTS

### 9.1 SC SERIES

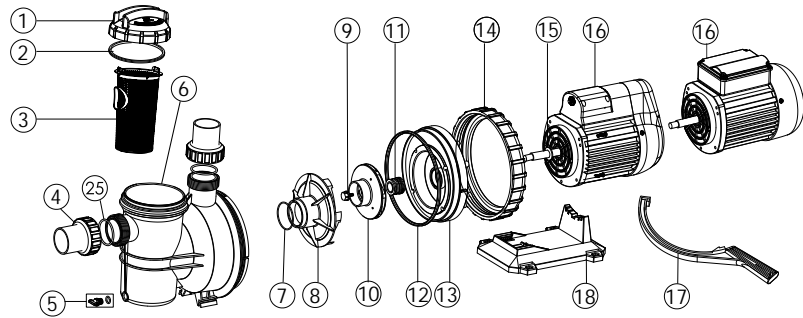

Key No.	Part No.	Description	QTY
1	01041043	Transparent Lid	1
2	02021088	O-Ring for Lid	1
3	01111076	Basket (Big)	1
4*	89280105	1.5" Union (Black/ White Colour)	2
5	89021307	Drain Plug With O'Ring	2
6	01111006	SC Pump Body	1
7	02011105	O-ring for Diffuser	1
8	01111009	Diffuser	1
9	89021704	Impeller Screw with O-ring	1
10	01311007	Impeller SC050(110V/60HZ) & (220V/60HZ)	1
10	01311008	Impeller SC075(110V/60HZ) & (220V/60HZ)	1
10	01311009	Impeller SC050(220V/50HZ) & (380V/50HZ)/ SC100(110V/60HZ) & (220V/60)	1
10	01311010	Impeller SC075(220V/50HZ) & (380V/50HZ)/ SC150(110V/60HZ) & (220V/60HZ)	1
10	01311011	mpeller SC100(220V/50HZ) & (380V/50HZ)/ SC200(110V/60HZ) & (220V/60HZ)	1
10	01311012	Impeller SC150(220V/50HZ) & (380V/50HZ)	1
10	01311013	Impeller SC150(220V/50HZ) & (380V/50HZ)	1
11	E020001	3/4" Mechanical Seal	4
12	02011089	O-Ring for Flange	1
13	01111008	SC Pump Flange	1

Key No.	Part No.	Description	QTY
14	01021014	Ring Lock Nut	1
15	02011096	Motor Slinger	1
16	89021705	Motor SC050(220V/50HZ)	1
16	89021706	Motor SC075(220V/50HZ)	1
16	89021707	Motor SC100(220V/50HZ)	1
16	89021708	Motor SC150(220V/50HZ)	1
16	89021709	Motor SC200(220V/50HZ)	1
16	89021801	Motor SC050(220V/60HZ)	1
16	89021802	Motor SC075(220V/60HZ)	1
16	89021803	Motor SC100(220V/60HZ)	1
16	89021804	Motor SC150(220V/60HZ)	1
16	89021805	Motor SC200(220V/60HZ)	1
16	89022001	Motor SC050(380V/50HZ)	1
16	89022002	Motor SC075(380V/50HZ)	1
16	89022003	Motor SC100(380V/50HZ)	1
16	89022004	Motor SC150(380V/50HZ)	1
16	89022005	Motor SC200(380V/50HZ)	1
16	89021901	Motor SC050(110V/60HZ)	1
16	89021902	Motor SC075(110V/60HZ)	1
16	89021903	Motor SC100(110V/60HZ)	1
16	89021904	Motor SC150(110V/60HZ)	1
16	89021905	Motor SC200(110V/60HZ)	1
17	01021022	Opening Key	1
18	01111007	Base	1
19	89021311	Cable Box for SC Pump (220V/50Hz)	1
20	89021505	Cable Box for SC Pump (110V/60Hz)	1
21	04016019	Capacitor for SC050 & SS/SD/SQ/ST075 Pump (110V)	1
21	04016021	Capacitor for SC075 & SS/SD/SQ/ST100-124 Pump (110V)	1
21	04016022	Capacitor for SR/SB10-15 & SC100-150 Pump (110V)	1
21	04016023	Capacitor for SR/SB20-30 & SC200 Pump (110V)	1
21	04016010	Capacitor for SS/SD/SQ/SP/ST075 & SC050 Pump	1
21	04016012	Capacitor for SS/SD/SQ/SP/ST100-120/ SC075	1
21	04016014	Capacitor for SB/SR10,SB15/ SC100/ SC150	1
21	04016015	Capacitor for SB/SR20 & SC/EPH200 & SPH200 Pump	1
22	01031007	Cooling Fan for SC SB/SR10,SB/SR15	1
23	01031009	Fan Cover for SB/SR10,SB/SR15 Pump (220V/50Hz)	1
24	01031002	Fan Cover for SB/SR10,SB/SR15 Pump (110V/60Hz)	1
25	02011104	O-Ring for 1.5" Union	2



Note: 4\* 89280105B is 1.5" Union is in Black Color  
 4\* 89280105W is 1.5" Union is in White Color

## 9.2 SCUS SERIES

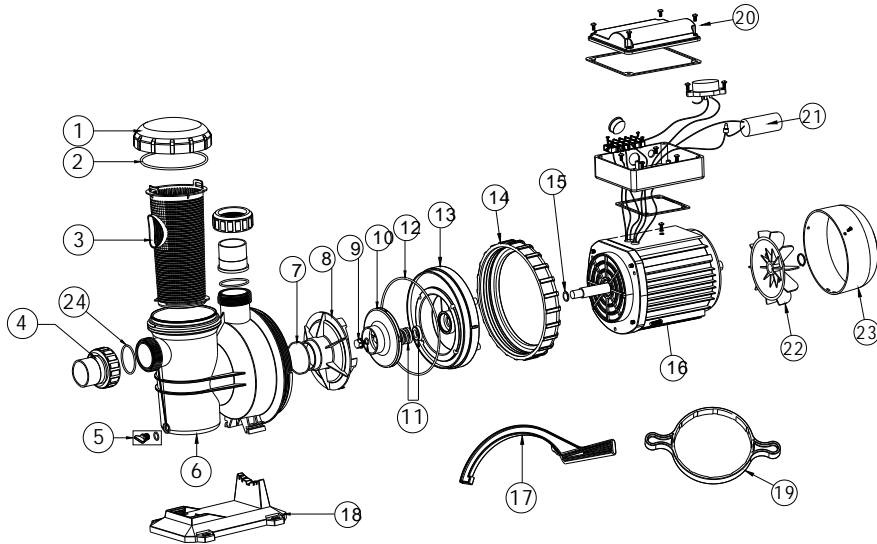

Key No.	Part No.	Description	QTY
1	01041046	Transparent Lid	1
2	02021088	O-Ring for lid	1
3	01111076	Basket (Big)	1
4	89280105B	1.5"union(Black)	2
5	89021307	Drain Plug With O-ring	1
6	01111006	SCUS Pump Body	1
7	02011105	O-ring for Diffuser	1
8	01111009	Diffuser	1
9	89021704	Impeller Screw with O-ring	1
10	01311009	Impeller SCUS100(115/230V 60HZ)	1
10	01311010	Impeller SCUS150(115/230V 60HZ)	1
10	01311011	Impeller SCUS200(115/230V 60HZ)	1
11	E020001	3/4"Mechanical seal	1
12	02011089	O-ring for Flange	1
13	01111008	SC Pump Flange	1
14	01021014	Ring Lock Nut	1
15	02011096	Motor Slinger	1

Key No.	Part No.	Description	QTY
16	04020096	Motor SCUS100(115/230V 60HZ)	1
16	04020097	Motor SCUS150(115/230V 60HZ)	1
16	04020098	Motor SCUS200(115/230V 60HZ)	1
17	01021022	Opening Key	1
18	01111007	Base	1
19	01020014	Key for transparent Lid	2
20	89021505	Cable Box for SCUS Pump	1
21	04016041	Capacitor for SCUS100-SCUS150 Pump	1
21	04016042	Capacitor for SCUS200 Pump	1
22	01031007	Cooling fan for SC SB/SR10,SB/SR15/SCUS	1
23	01031002	Fan Cover for SB/SR10,SB/SR15 Pump/SCUS	1
24	02011104	O-Ring for 1.5" Union	2

## 10. TERMS OF THE WARRANTY

As original purchaser of this equipment have purchased from Emaux Water Technology Co Ltd, through Authorized International Distributor or Dealer, warrants its products free from defects in materials and workmanship under normal use during warranty period. The warranty period begins on the day of purchase and extends only to the original purchaser. It is not transferable to anyone who subsequently purchases the product from you. It excludes all expendable parts.

During the warranty period, Emaux authorized reseller will repair or replace defective parts with new parts or, at the option of Emaux, serviceable used parts that are equivalent or superior to new parts in performance.

This Limited Warranty extends only to products purchased from Emaux authorized reseller. This Limited Warranty does not extend to any product that has been damaged or rendered defective

- (a) as a result of accident, misuse or abuse;
- (b) as a result of an act of God;
- (c) by operation outside the usage parameters stated herein;
- (d) by the use of parts not manufactured or sold by Emaux;
- (e) by modification of the product;
- (f) as a result of war or terrorist attack; or
- (g) as a result of service by anyone other than Emaux authorized reseller or authorized agent.

EXCEPT AS EXPRESSLY SET FORTH IN THIS WARRANTY, EMAUX MAKES NO OTHER WARRANTIES EXPRESSED OR IMPLIED, INCLUDING ANY IMPLIED WARRANTIES OR MERCHANTABILITY AND FITNESS FOR A PARTICULAR PURPOSE. EMAUX EXPRESSLY DISCLAIMS ALL WARRANTIES NOT STATED IN THIS LIMITED WARRANTY. ANY IMPLIED WARRANTIES THAT MAY BE IMPOSED BY LAW ARE LIMITED TO THE TERMS OF THIS EXPRESS LIMITED WARRANTY.