



SUPERIOR SUC SERIES SALT CHLORINATOR INSTALLATION & USER MANUAL



CONTENT

1. Safe Pool Sanitizing Working Principle	3
2. Product Features	3
3. Water Chemistry	4-6
4. Product Specification	6
5. Installation Guide	7-9
6. Operation Start Up	9
7. Control Panel operation	10-11
8. Timer setting for Timer version	12
9. Maintenance and Troubleshooting	12
10. Troubleshooting	13
11. Clean Chlorinator Titanium Cell	14
12. Warranty Policy	14-16
13. Replacement Parts	17-19
14. Installation Template	19

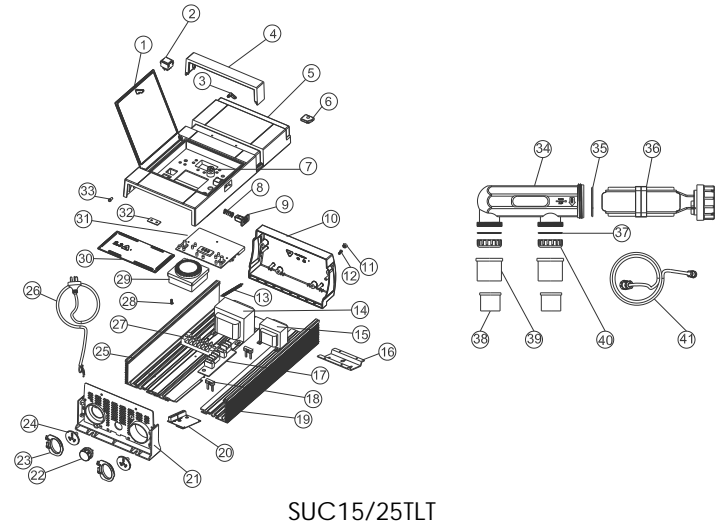

SUC15/25TLT



14. Installation Template
Ratio 1:1

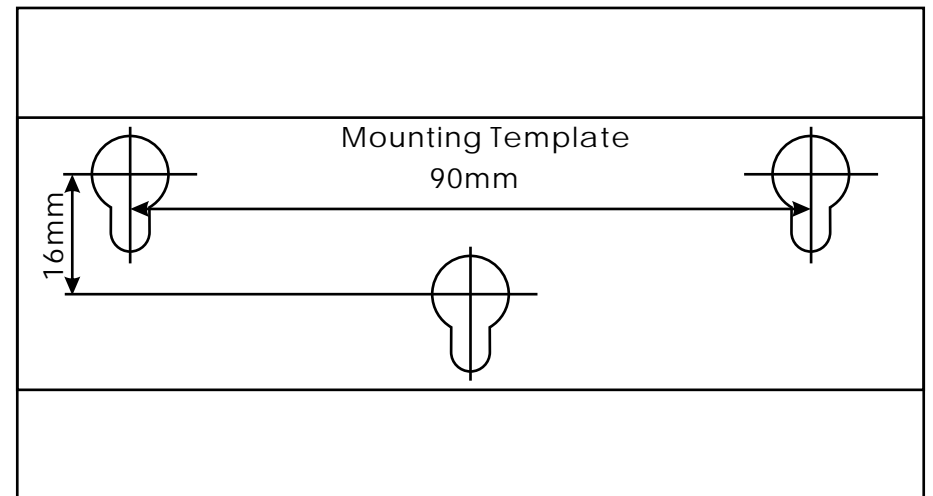

Item	Part No .	Description	Qty
31	1062570094	SUC15 PCB Control Complete (ver 5.7)	1
31	1062570095	SUC15 PCB Control Complete (ver 5.7)	1
32	530110445	cable clamp	1
33	570646784	binder	1
34	530040442	Cell Housing	1
35	111192492	O-Ring for Housing	1
36	08050018	Replacement Cells for SSC15	1
36	08050019	Replacement Cells for SSC25/50	1
37	111040008	O-Ring for Union	2
38	430300943	1.5" Union	2
39	430300989	2.0" Union	2
40	430170991	2.0" Union Nut	2
41	89380215	Salt Chlorinator Cable Set	1

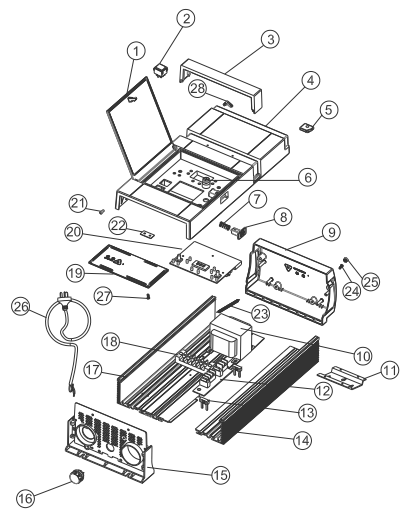

SUC15/25/50E

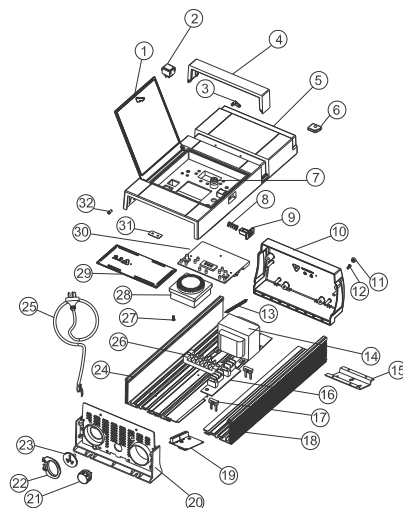

SUC15/25/50T

Caution:

This appliance can be used by children aged from 8 years and above and persons with reduced physical, sensory or mental capabilities or lack of experience and knowledge if they have been given supervision or instruction concerning use of the appliance in a safe way and understand the hazards involved. Children shall not play with the appliance. Cleaning and user maintenance shall not be made by children without supervision. If the supply cord is damaged, it must be replaced by the manufacturer, its service agent or similarly qualified persons in order to avoid a hazard.

The control unit can connect to one pump and one underwater light only (Superior SUC-TLT Series Only) The current loading of the pumped connected must not exceed 8 Amp. (Superior SUC-TLT Series Only)

1. Safe Pool Sanitizing Working Principle

The chlorinator uses electrolysis to break down the salt (NaCl) in the swimming pool to form Chlorine (Cl₂). The control unit of the chlorinator can regulate the chlorine production by altering the electric current flow through the titanium electrode in the cell housing. Chlorine is an effective sanitizing agent which is commonly used in swimming pools, it can inhibit the growth of bacteria and fungi.

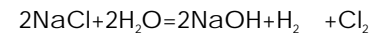

2. Product Features

- Convenience and the constant delivery of pure chlorine-based sanitizer.
- No more artificial chemical cleaning agent which could cause skin and eye irritation. You just need to add natural salt in the pool.
- The salt in the water is so little you do not taste or smell the salt.
- The electrode is made of titanium, which is durable and resistant to corrosion.
- Easy to install and operate.
- The water does not have the heavy smell of chlorine because chlorine is not directly added to the pool.

Product Picture



1x control box



1x cell



1 set 1.5" / 2" Universal Union



1 x cell cable



1 set screws and Fuse



User Manual

Product Dimension

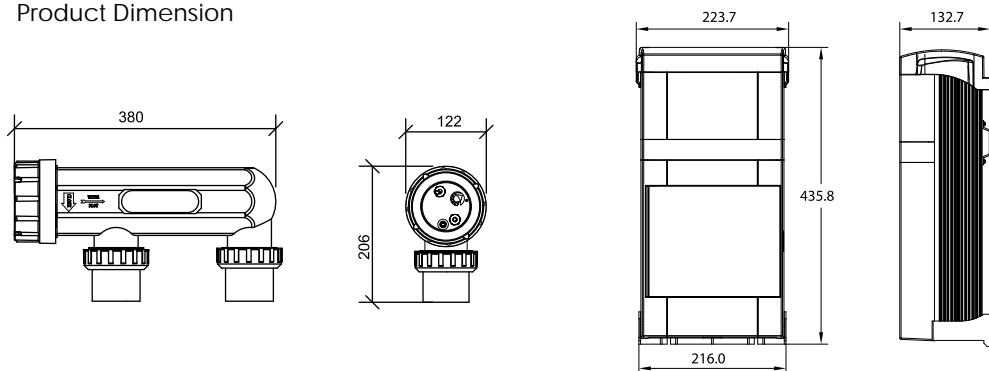

3. Water Chemistry:

It is important to note that the EMAUX Superior Chlorinator does not maintain the water chemistry of your swimming pool water; it simply produces chlorine from a mild salt solution.

To ensure that your chemical balances are within the guidelines listed below you should also have your water tested regularly at your local pool shop to encourage a sparkling clean healthy pool.

Salt level	SUC15-E / SUC15-T / SUC15-TLT	3000 - 4000 ppm
	SUC25-E / SUC25-T / SUC25-TLT	3000 - 4000 ppm
	SUC50-E/SUC50-T	4000 - 5000 ppm
Free Chlorine	1.0 - 3.0 ppm	
pH	7.2 - 7.6	
Cyanuric acid (stabilizer)	30 - 50 ppm	
Total Alkalinity	80 - 120 ppm	
Calcium Hardness	200 - 400 ppm	
Metals	0 ppm	

Chlorine Level Calculation

$$\text{Required Chlorine Production Rate (g/hr)} = \frac{\text{Pool Volume (litre)} \times \text{Standard Chlorine (g/litre)}}{\text{Turnover Rate (Hr)}}$$

Standard Chlorine Level not less than 2mg/liter = 0.002g/liter

Example:

Pool Volume: 65m³ = 65,000litre

Turnover Rate: 4 Hour

Required Chlorine Production Rate (g/hr) == 32.5g/hr

13. REPLACEMENT PARTS

Item	Part No .	Description	Qty
1	530096784	Door Model	1
2	106171405	Switch I O II 250VAC	1
3	570966784	roller	1
4	530186785	Bar Model SUC	1
5	530086784	Front Panel	1
6	570336784	wall Hanger	1
7	89380201	Fuse 2.5A with socket SUC15	1
7	89380218	Fuse 6.3A with Socket SUC25 /25	1
8	112010051	spring	1
9	570636784	Lock	1
10	530066784	Top Cover	1
11	111040047	silicon stopper	4
12	112002636	M4 x 10 Screw	31
13	112062661	Spring	1
14	106166313	Transformer for SSC15	1
14	106166314	Transformer for SSC25	1
15	106161579	Transformer for Lighting	1
16	116113342	Hanging Bracket	1
17	1064470088	SSC15 Silicon controlled combination (er1.4)	1
17	1064470089	SSC25 Silicon controlled combination (er1.4)	1
18	106147161	Fuse 20A	2
19	1160970007	Heat Sink B	1
20	106015531	EMC Board (with Light) (er2.0)	1
21	530100444	Bottom Panel Comp	1
22	106485903	SP Power Point 2112 /5	1
23	E130025	Component Enclosure Plate	2
24	106111391	250V /10A Jack for Australia	2
25	1160970006	Heat Sink A	1
26	105021259	Power Cord France	1
27	106415534	Terminal block	1
28	112232743	M3 x8 screw	10
29	106591524	Timer Analogue Battery Pack	1
30	530076784	Protecton sheet	1

2. Once the complaint is received, the product quality incident will then be reviewed by Emaux's Quality Department following the "Emaux Warranty Policy".
3. Conclusion: After the investigation is completed, Emaux will inform the distributor accordingly.

12.3. WARRANTY OBLIGATION

Emaux warrants any of above items from workmanship and/or material(s). Should a defect become evident during the term of warranty, Emaux will, at its option, repair or replace such item or part at its own cost and expense. Customer will need to follow the warranty claim procedures from Emaux in order to obtain the benefit on this warranty.

Emaux is not, however, responsible under this warranty for any cost of shipping or transportation of the equipment or parts thereof "to" or "from" our technical operations. Emaux is not able to liable for any loss of time, inconvenience, incidental expenses such as labor cost, phone calls, legal cost or material cost incurred in connection with the replacement or removal of the equipment, or any other consequential or incidental damage on persons or assets. Emaux will be not responsible for any business profit loss operation stop due to the non-conformity product equipment. No indemnity or damages can be claimed on any account whatever.

12.4. WARRANTY OR REPRESENTATIONS BY OTHERS

No dealer or other person has authority to make any warranty or representation concerning Emaux or its products. Accordingly, Emaux is not responsible for any such warranty or representation.

SALT LEVEL

The amount of salt required is between 4000 and 6000 ppm. This means to add directly in the pool water 4 kg/m³.

Low concentration of salt (below 2500 ppm) will cause premature cell failure. High concentration of salt (above 6000 ppm) may cause electro-oxidation and corrosion damage to the Stainless Steel pool fixtures.

Salt required according to the volume of the pool:

Pool volume (m ³)	Salt (kg)	Pool volume (Gallon)	Salt (Pound)
10	40	2,642	88
15	60	3,963	132
20	80	5,283	176
25	100	6,604	220
30	120	7,925	264
35	140	9,246	308
40	160	10,567	352
50	200	13,209	440
60	240	15,850	528
70	280	18,492	616
80	320	21,134	704
90	360	23,775	792
100	400	26,417	880
110	440	29,059	968
120	480	31,700	1,056
150	600	39,626	1,320

NOTE: Table based on 4000 ppm of salt per m3 of water.

TYPE OF SALT

The most common salt used in swimming pools with Salt Electrolysis is Sodium Chlorine (NaCl) that is 99% pure.

DO NOT use the following types of salts:

- Rock salt.
- Salt with more than 1% yellow prussiate of soda.
- Salt with more than 1% of anti-caking additives.
- Iodized salt.

ADDITION AND REMOVING SALT IN THE SWIMMING POOL WATER

Before adding the salt into the pool, place the multiport valve on “Filtration” or “Recirculation” and then turn the filtration pump on.

Add the salt directly into the pool or ballast tank and do not allow the salt to sit in a pile on the bottom of the pool.

Keep the filtration system running for 24 hours using the Main Drain or vacuum suction nozzle as a main suction line.

The only way to remove the salt in the pool water is to partially drain the pool and refill with fresh water.

4. Product Specification

Model	Cell Power Rating	Chlorine Generation	Fiberglass Pool	Concrete Pool
	(VA)	(g/hr)	(Liter)	(Liter)
SUC15-E	142	15	50000	45000
SUC25-E	226	25	75000	70000
SUC50-E	500	45	120000	110000
SUC15-T	142	15	50000	45000
SUC25-T	226	25	75000	70000
SUC50-T	500	45	120000	110000
SUC15-TLT	142	15	50000	45000
SUC25-TLT	226	25	75000	70000

* All the cells are Self Cleaning type

SUC-TLT Series (Chlorinator with underwater light, transformer and time switch)

Model	Input Voltage / Frequency	Underwater light transformer Power Rating
SUC15-TLT	220-240VAC50/60Hz	100VA
SUC25-TLT	220-240VAC 50/60Hz	100VA

SUC-T Series (Chlorinator with time switch)

Model	Input Voltage / frequency	Power Rating
SUC15-T	220-240VAC50/60Hz	142VA
SUC25-T	220-240VAC50/60Hz	226VA
SUC50-T	220-250VAC50/60Hz	500VA

EXTENDED WARRANTY FOR SPECIFIC PRODUCTS	
(OFFERED FROM DATE OF INVOICE)	
Product	Warranty Period
Filters & Filter Systems	2 years
Pumps	1 year
Underwater Lights	1 year (bulbs 90 days)
Ladders	1 year
Control devices	1 year
Heat Pumps & Heat Exchangers	1 year
Salt Chlorinators & UV Systems	1 year (2 years for cell material)
Pool Fittings	1 year
Cleaning Equipment & All others	1 year

12.1. EXCEPTIONS THAT MAY RESULT IN DENIAL OF A WARRANTY CLAIM

1. Damage caused by careless handling, improper repackaging or shipping.
2. Damage due to misapplication, misuse, abuse or failure to operate and install the equipment as specified in this manual.
3. Damage caused by a misuse, abuse or failure to operate and install the equipment out of the scope of a professional level demanded in similar equipment or installation type.
4. Damage due to unauthorized product modifications or failure to use Emaux original replacement parts.
5. Damaged caused by negligence or failure to properly maintain products as specified in this manual.
6. Damage caused by failure to maintain water chemistry in conformity with the standards of the swimming pool industry for any length of time.
7. Damage caused by water freezing inside the product.
8. Accident damage, fire or other circumstances outside the control of Emaux.
9. Items had been repaired or altered in any way by any person that is not authorized by Emaux.
10. Wear & tear parts.

12.2. CLAIM PROCESS

Summary of Emaux Claim Process in 3 steps:

1. Claim: Customer contacts Emaux salesperson and provides completed details of the claim which includes:
 - a. Information about the failed product such as the part number(s) and serial number(s).
 - b. Description of the complaint/failure.
 - c. Pictures

11. Clean Chlorinator Titanium Cell

Even the system is design in cell cleaning function, cleaning your Salt Water Chlorinator Cell is required to remove calcium from the plates of the cell which is a by-product of chlorination.

Protection Caution

The mixture required for cleaning is extremely corrosive and protective wear is highly recommended.



Procedures

1. Make a cleaning mixture of 1/10 parts Hydrochloric Acid to water (Always add Hydrochloric acid to water).
2. Turn the filtration system off.
3. Remove Salt Cell from the housing.
4. Add the Salt Cell to the cleaning mixture making sure there is little to no contact with the terminals.
5. Wait five to ten minutes for the Salt Cell to be cleaned.
6. If any parts of calcium are stuck or will not dissolve, carefully remove them with a smooth plastic instrument.
7. Once the Salt Cell is clean, rinse with fresh water and place back in the housing and tighten the cell or collar.
8. Turn system back to automatic setting or timer.
9. Dispose of cleaning mixture.



If the Salt Cell has an increased amount of calcium and it has not been removed after the ten minutes in the cleaning solution it is advised to use a specialty product "Cell Cleaner" which is not as corrosive or damage the cell in any regard. The cell can be left in Salt Cell Cleaner for up to 1 hour and will completely remove calcium.

We recommended using Salt Cell Cleaner at all times over the traditional Hydrochloric mixture, it is a safer alternative and not harmful to your Salt Cell at all and reusable.

12. WARRANTY POLICY

Emaux manufactures its products with the highest standard of workmanship, using the best materials available through state of the art process. Emaux proudly warrants its products as follows:

5. Installation Guide

The Emaux Superior SUC Chlorinator unit is contained in a rain tight enclosure that is suitable for outdoor mounting (IPX4 waterproof). However, the following points must be taken into consideration for a correct installation of the Superior SUC Chlorinator unit:

- Select a convenient well-ventilated location within one meter of filter equipment.
- Install the Control Panel using the template paper sheet provided with the package in a minimum distance of 3.5 meters (11.5 ft.) from the swimming pool, 1.5 meters (5 ft.) from the ground, within 2 meters (6.5 ft.) from the protected outlet, and within 4.5 meters (15 ft.) from where the cell will be installed, in a ventilated area and leaving enough free space of min. 50 cm (20") in each side for servicing.



Mounting bracket

- Two self-tapping screws and wall plugs have been provided for fast and simple installation. Simply cut out Template provided for the location of drill entry points. Use a 8mm masonry drill when fitting control unit to a brick or concrete wall. When mounting to a post drill pilot holes and fit screws provided. Once screws are in position simply hang the chlorinator via the bracket on back of Control Box.
- The electrolytic cell housing must be plumbed into the return line after the filter. Please refer to the installation diagram. The cell housing can be fitted to 1.5" or 2" PVC piping by provided universal union.
- Glue the salt cell horizontally on the pool return pipe, allow 24 hour curing of the pipe glue.
- Used the provided cable to connect the control unit and the salt cell together.

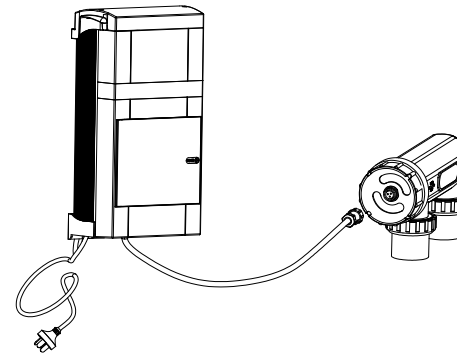

- DO NOT mount the Control Panel in a direct sun light.
- The Control Panel must be installed far away from the chemical storage, especially from acid because it can corrode the electronics inside the unit.
- It must be kept away from heat sources and any equipment which produce heat.
- Plug-in power supply into a suitable weatherproof outlet socket with circuit breaker.
- Before fixing the Control Panel, make sure that the power cable and cell cable also reach the Control Panel.

Electrolytic Cell and Electrode

- The cell must be installed horizontally
- Connect the water inlet and outlet to the Cell Unit. The water flow direction must be as indicated on the Cell.
- To avoid loss of chlorine, the Cell should be installed at the end of the filtration system, right before the pool water return.

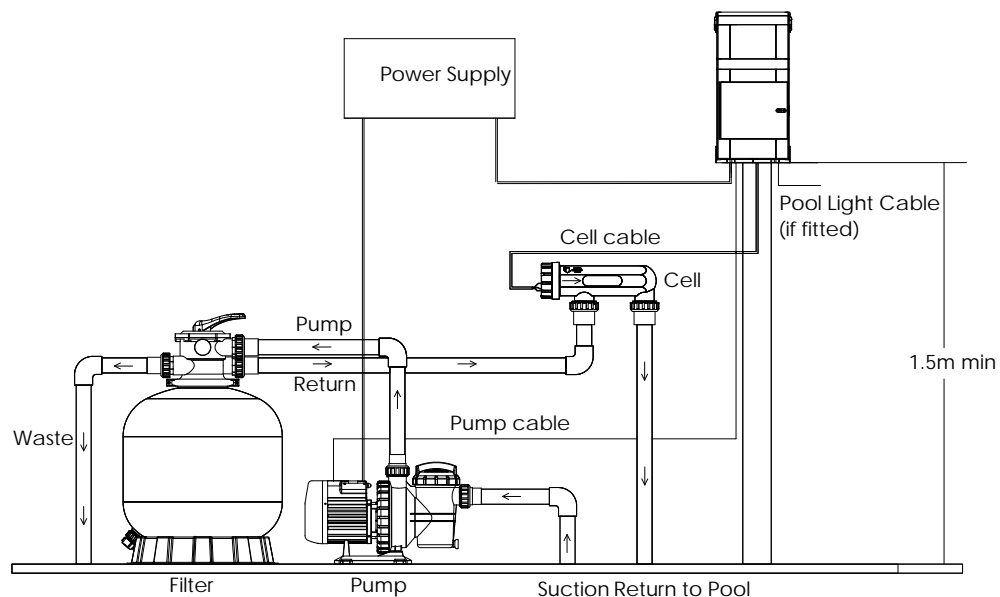

10. Troubleshooting

i. Low / no chlorine production	How to handle
Salt level is too high and cause over heat.	Check the salt level is within operation range, refer to individual model recommendation. It will resume output when salt level is normal.
Check the electrical plug / control box / pump power	Connect the power properly
Setting system is too low	Turn the system control to maximum
Automatically stopped by the timer setting	Adjust the timer setting
Blown fuse	Cut the power and replace the fuse
excessive scale build upon the cell	Switch off the salt chlorinator and clean the salt cell by professional serviceman.
Filter Backwashing	Once the backwash is complete, turn the filter back to normal filtration
The gas sensor is not connected	Connect the gas sensor according to this manual
Pump malfunction	Stop the filtration system and repair the pump
Water temperature too low	Turn on the winter switch
Salt lever too low	Add salt to the pool
pH valve too high	Check the water pH valve and keep it around 7.0-7.6
ii. No flow	
Pump malfunction	Stop the filtration system and repair the pump
Filter Backwashing	Once the backwash is complete, turn the filter back to normal filtration
The gas sensor is not connected	Connect the gas sensor according to this manual
iii. No display	
Setting system is too low	Turn the system control to maximum

8. Timer setting for Timer version

- Turn the outer clock face until the time of the day is aligned with the clock at the center of the timer
- The 24-hour dial has 15 minutes division. The timer can be programmed by pushing the captive trippers to the outer ring position for the entire period that the load is to return ON.
- The timer clock will rotate with time; the chlorinator will be turned on automatically if its captive tripper is pushed outward.

9. Maintenance and Troubleshooting

Salt Chlorinators are a valuable piece of pool sanitizing equipment and must be cared for to get the best performance and life span from it.

- Keep the water chemical balance
- Good operation environment
- Regular check of the titanium plates. During the chlorination process a white powder Calcium scale may naturally build up on the titanium plates in the cell. Regular monitor of the cell to prevent excessive scale build up. Excessive scale build up will cause damage to your cell, and dramatically reduce its efficiency and lifespan.
- If the control box failure or calcium excessive build up, maintenance must be carried out by professionals.
- Avoid any insect from entering the control box, it may damage the electrical component inside.
- Regular monitor of the filter and pump

For model with lighting power output installation

Mount the control unit vertically onto a post or wall 1.5 meters above ground level. (Australian Standards requires that the electric control unit shall not be located within 3 meters of the pool water.)

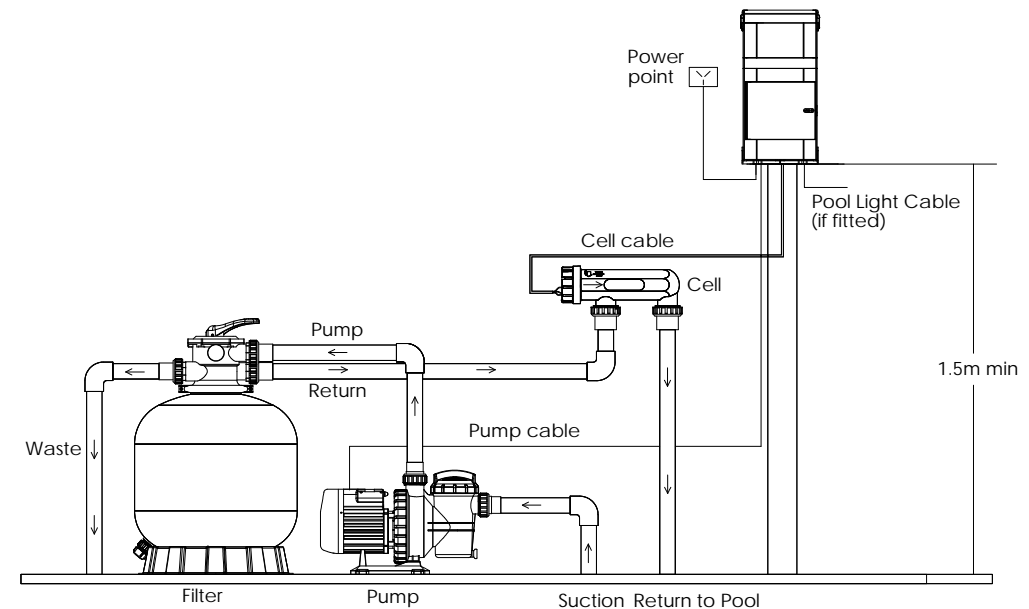

6 . Operation Start Up

- Power input : 220-240VAC, 50/60Hz
- Recommended pool salt level: 4000PPM (no less than 40kg of pure salt dissolved in 10,000 liter of pool water)
- Run chlorinator at the Salt Levels stated within this document and on the product to ensure optimum sanitizer output and cell life.
- Operating this device at low salt levels will damage the cell and reduce its life.
- The control panel will displays a RED indicator when the salt level is low.
- If no action is taken to rectify the salt level, damage to the cell may result which will not be covered under warranty.
- During extreme hot weather conditions or high bather load, the pool water need to be super-chlorinated using granulated or liquid chlorine or increase the running time of the chlorinator.
- Always turn down the system control to zero before adding salt, once the salt is completely dissolved, return to the set position.
- The aluminum casing at the back of the Control Unit acts as a heat sink, do not touch it with bare hands.

7 . Control Panel operation

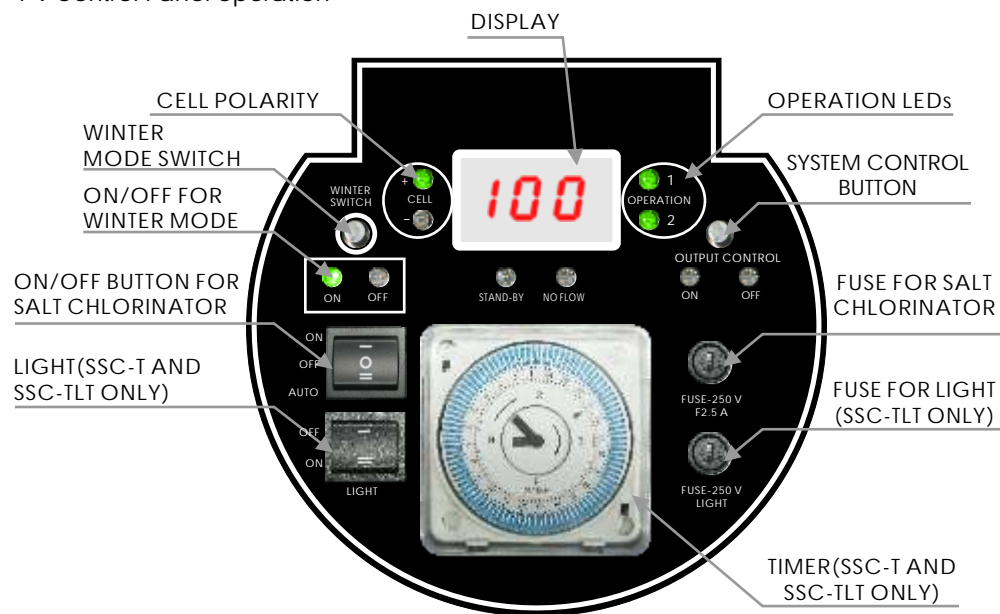

3 Digital display

There are three display function

- When system control button is pressed, it adjust the cell output ratio and display the corresponding running time per hour. For example, "100 " means 60 minutes, "50" means 30 minutes run and 30 minutes idle.
- In normal operation, it represent the percentage of the chlorine production. "100" means it is 100% chlorine is generating with adequate salt level.
- System Error code, system stop and need attention

Error code	Description	Solution
ER2*	Terminal inside temperature is too high	Power off the unit, open the case to check the cell terminal screw is tight enough or not. Restart the system.
ER3	Thermal sensor is disconnected	Check the sensor cable is loss or not
ER4	AC line input issue	Check the transformer output wiring, or fuse is broken

* ER2- the system stop operate for protection when extremely worst operation environment is detected, with too high salt level, high ambient temperature or without ventilation.

LED display

	1	2	Description
Operation	Green	Green	Normal Operation
	Green	Red	Low salt/Deposition on the electrode/Low water Temperature
	Red	Red	Extremely low salt level/ series deposition on the electrode/extremely low water temperature
System Control	ON	OFF	Description
	Green		System control less than 100%, under operating
		Red	System control less than 100%, under idle time
Cell Polarity	+	-	Description
	Red		The cell current in positive direction
		Red	The cell current in negative direction

SALT CHLORINATOR ON/OFF/AUTO: ON/Off Switch. In Auto mode, the chlorinate is operated by the timer setting

Light On/Off: Switch for underwater light connected to the control unit (For certain model)

System Control button: Adjust the chlorine product of the chlorinator in term of time. For example:

Set at 100% = the salt cell operate continually.

Set at 50% = the salt cell operate 30 minutes of each hour and 30 minutes is idle.

Set at 30% = the salt cell operate 18 minutes of each hour and 42 minutes is idle.

Winter Mode Switch and On/ Off LED: Turn on to change the chlorine production at 85% .

Cell Polarity LED: Show the polarity of the electrodes; the polarity of the electrode will shifted every 8 hrs of operation, so as to clean the deposition on the electrode.

Timer: Used to set the program to turn on and off the control unit automatically. (for model with timer only)

Stand-By LED: Turn on when chlorinate is in stand-by mode, When the chlorinator is turn on, the standby LED will go off after 35 sec.

No Flow LED: Turn on if there is no water flow, if there is no water flow, the pump and salt chlorinator will stop automatically.