

Maintenance of the Lights

- 1) Do not leave the lights "on" above water for longer than 1 minute.
- 2) Do not leave the lights directly under sunlight. Fill the pool with fresh water as soon as possible after the lights are installed.
- 3) Before switching on the lights, check whether the lights are fully submerged underwater and the circuit boxes are running properly.
- 4) This unit does not need any kind of maintenance. If it is not working properly, please contact EMAUX authorized dealer where you purchase the unit from.
- 5) Warranty will be voided if the Emaux Underwater Light was dismantled by unauthorized personnel.

REPLACEMENT PARTS

Item	Part No.	Description	Qty
1	03011334	M5x30 Screw	1
2	89045901	LED Panel (Cool White)	1
	89045902	LED Panel (RGB)	
	89045903	LED Panel (Warm White)	
	89045904	LED Panel (Single Blue)	
3	01050166	Cable clip	4
4	03011307	M4x12 Screw	4
5	89040203	Fitting for Concrete pool	1
6	89045517	Fitting for vinly pool	1

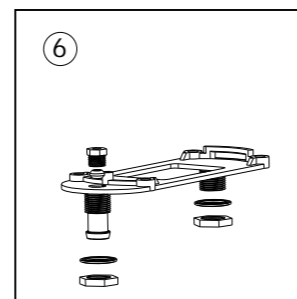
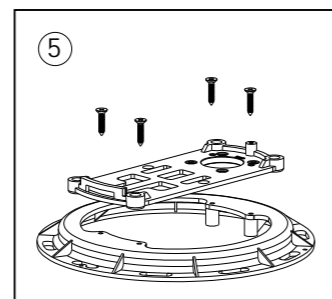
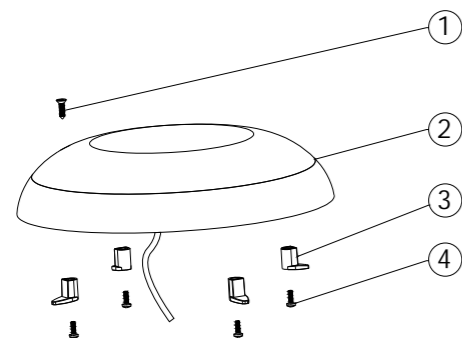

www.emauxgroup.com

Arr30

UNDERWATER LIGHT OPERATING MANUAL

Model : Arr30CW / Arr30B / Arr30C / Arr30W

Keep this manual for future reference

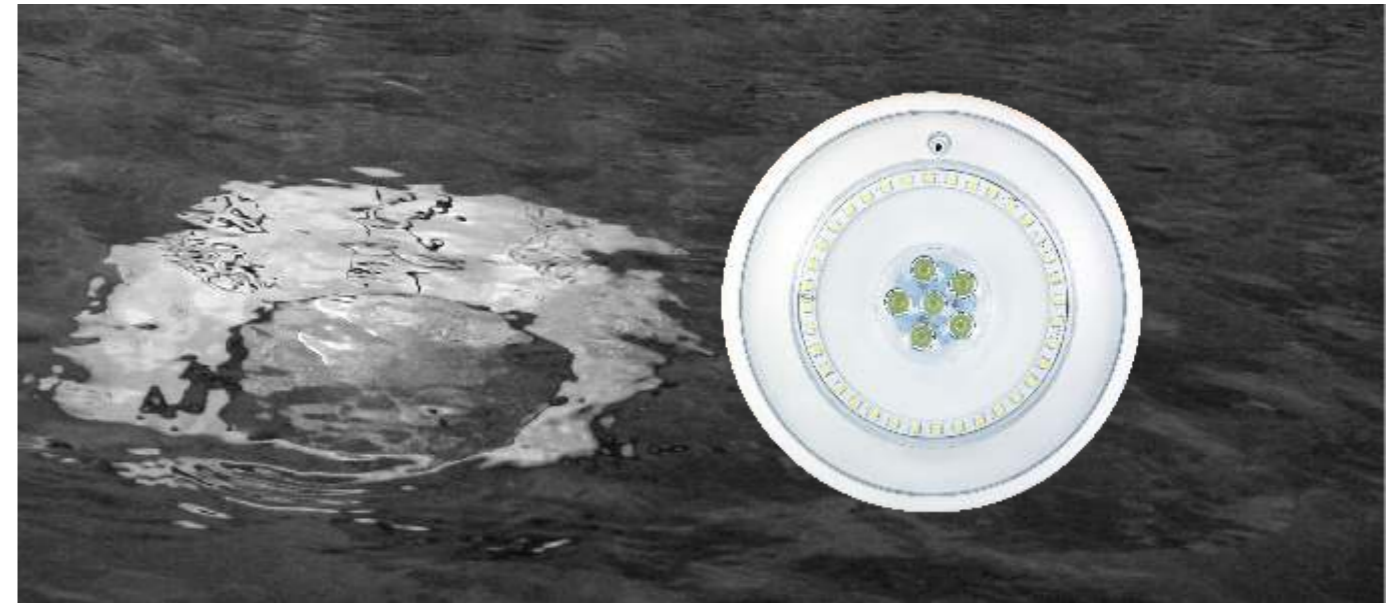

SAFETY WARNINGS

- Only qualified electrician is allowed to carry out the installation of this product.
- Avoid direct contact with electrical power.
- Respect all regulations in effect for preventing accidents.
- All units are required to be disconnected from the main electricity before any operation of maintenance.
- Never handle with wet hands and feet.
- This unit is design for use only when fully submerged in fresh water, connecting with a safety transformer.
- Never operate this Underwater Light for more than 1 minute unless it is totally submerged in water.
- Be sure power is off before installing or removing LED plate. Allow LED plate to cool before replacing.
- This product should be installed according to your local electrical installation ordinances and regulations.
- Maximum Depth for Light installation at 1 meter.
- Maximum Water Temperature Range for light operation 0 - 30°C.
- For type Y attachments

If the external flexible cable or cord of this luminaire is damaged, it shall be exclusively replaced by the manufacturer or his service agent or a similar qualified person in order to avoid a hazard.

The light source of this luminaire is not replaceable, when the light source reaches its end of life the whole luminaire shall be replaced.

SPECIFICATION

- A) Electrical Specification : 1) Voltage : AC12V 2) Frequency : 50/60Hz 3) Power : 30W.
 B) Colour change options(For RGB version only) :

1	White	2	Green
3	Blue	4	Green+Blue
5	Red+Green	6	Red+Blue
7	Mode A: Blue+ Gradual Red	8	Mode B: Green+Gradual Red
9	Mode C: Blue+Gradual Green	10	Mode D: Blue+Gradual Red
11	Mode E: RGB Colour Sequence: Red>Green>Blue	12	Auto Colour Change
13	Mode F: Four Colour Sequence: Red>Green>Blue>Purple	14	Rapid Auto Colour Change

C) Control

- 1) When the light is connected to the transformer directly, the on/off switch controls the colour changes (Associating a light with a transformer and an on/off switch is recommended; If you want all the lights to change colour at the same time, install a master switch, Figure 1).
- 2) If applicable, when the light is connected to the transformer and the transformer to the optional control box, the control panel on the control box and its remote control controls the colour changes (See the Control Box Manual for details).

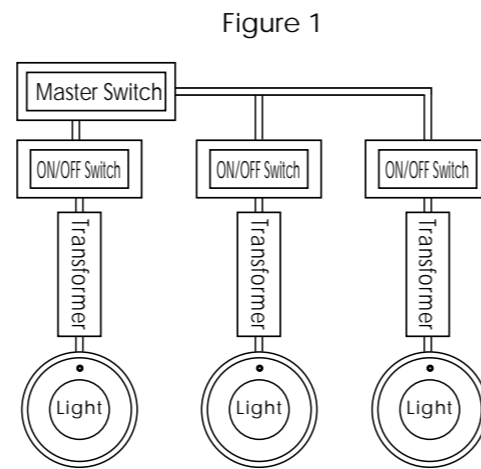

INSTALLATION NOTES

- 1) Each cable is 2.5m long. You should follow the procedures closely when installing the light.
- 2) It is recommended to install a light every 20m², the approximate exposure area of each unit.
- 3) The lights should be installed in the direction that they will not shine directly into the house.
- 4) For training or competition pools, the lights must be installed on the sides in order to prevent swimmers from seeing any glare.
- 5) Nothing should be placed on the poolside directly above the lights for ease of future maintenance.
- 6) If the wires are connected inside the lights, you must seal the connections with leak-proof tapes or products with the same function.
- 7) The cables connecting the lights and the transformers must be at least 6mm² and the distance between them must not exceed 30m (Figure 2); otherwise the lights will not function properly.

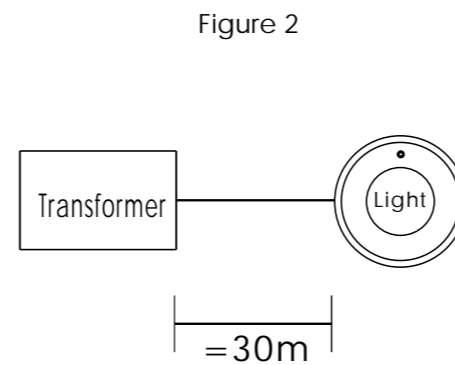

INSATALLATION OF THE UNDERWATER LIGHT

A) Preparing to Install

- 1) Before installation, a circuit system diagram must be designed by a certified engineer.
- 2) The circuit system must comply with local laws and regulations and must be carried out by qualified electricians.
- 3) Make sure the voltage is 12V and the terminal box is at least 120cm from the poolside (Figure 3).
- 4) Upon installation, top of the light must be at least 45cm from water surface (Figure 3).

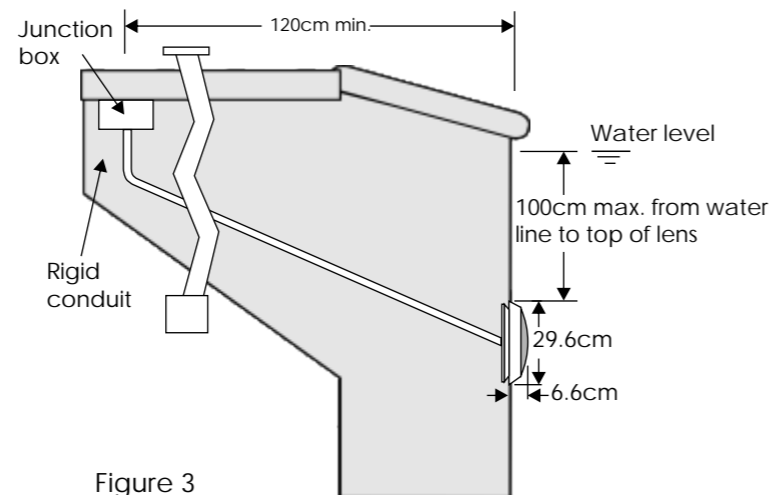

B) Pool Installation

- 1) Embed the Wall Mount into the concrete wall, making sure that it is parallel to the side of the pool (Figure 4).
- 2) Place the Mounting Plate on the concrete wall and tighten it with 4 screws. The conduit must be next to the Mounting Plate (Figure 5).
- 3) Note that the light must only be installed on a flat or concave surface.
- 4) Wrap extra cables behind the light to make sure it could be taken to the pool surface for future maintenance (Figure 6).
- 5) Hang the light onto the Mounting Plate and tighten the screws (Figure 7).
- 6) The wire connections inside the terminal box must be sealed by leak-proof tapes to prevent water from leaking into the terminal box through the cables.

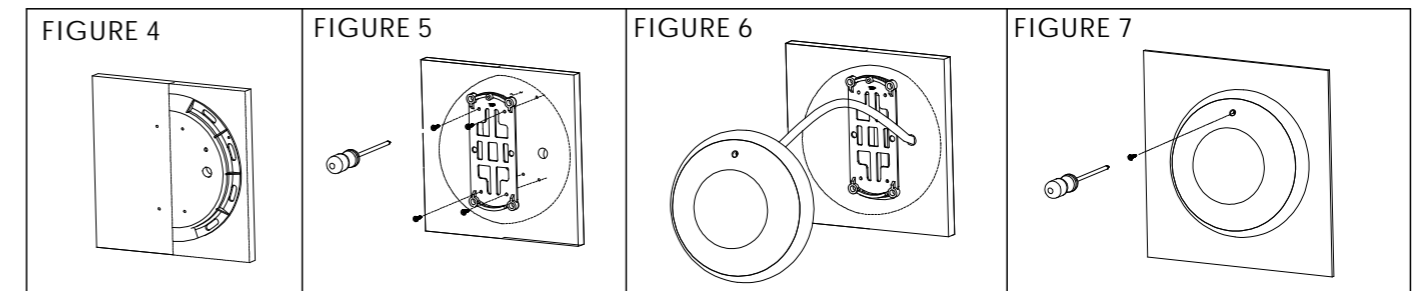

C) Fiberglass Pools / Vinyl Pools Installation

- 1) Refer to section "Preparing to Install".
- 2) Make 2 holes on the pool wall (Figure 8).
- 3) Place the o-rings between the Mounting Plate and the pool wall and tighten it with the Nut on the other side of the pool wall (Figure 9).
- 4) Put the cable sequentially through the sealing Nut, the sealing O-ring and the cable hole on the mounting plate; then tighten the Nut (Figure 10).
- 5) Wrap extra cables behind the light to make sure it could be taken to the pool surface for future maintenance. Then, hang the light onto the Mounting Plate and tighten the screws (Figure 11).

