

IV. Control

- 1) When the light is connected to the transformer directly, the on/off switch controls the colour changes (Associating a light with a transformer and an on/off switch is recommended; If you want all the lights to change colour at the same time, install a master switch, Figure 3).
- 2) If applicable, when the light is connected to the transformer and the transformer to the optional control box, the control panel on the control box and its remote control controls the colour changes (See the Control Box Manual for details).

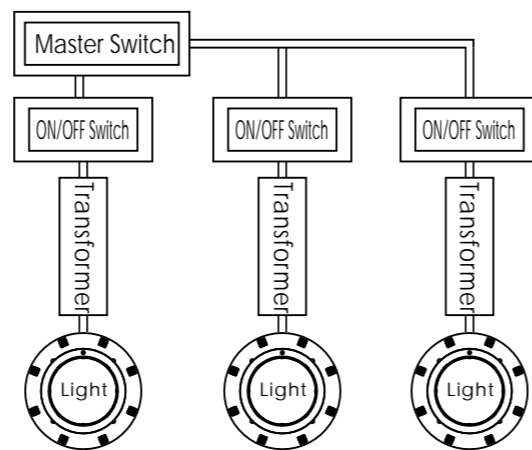
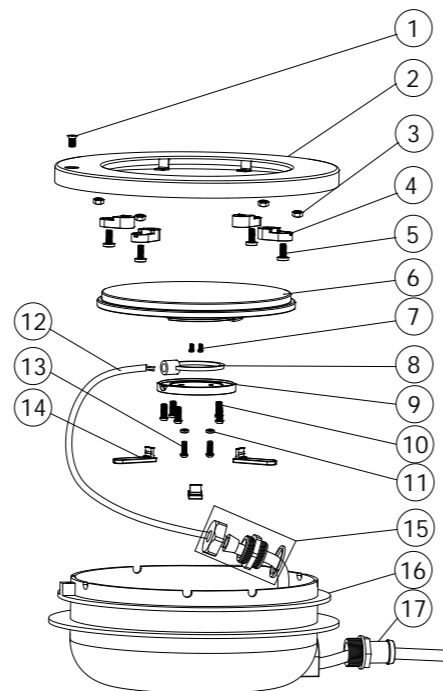

Figure 3

V. REPLACEMENT PARTS

Item No.	Part No.	Description	Qty
1	03011123	M5*10 Screw for Lid	1
2	03017138	Lid for EL-H200 Lighits	1
3	03013004	Hexagonal Nut (M4)	4
4	01110028	Fastener	4
5	03011348	M4*22 Screw	4
6	04011153	Ultra-Thin 252 LED panel 20W,Warm white	1
	04011151	Ultra-Thin 252 LED panel 20W,Cool white	
	04011152	Ultra-Thin 252 LED panel 20W,RGB	
	04011150	Ultra-Thin 252 LED panel 20W,Single Blue	
	04011107	Ultra-Thin 441 LED panel 35W,Warm white	
	04011105	Ultra-Thin 441 LED panel 35W,Cool white	
	04011106	Ultra-Thin 441 LED panel 35W,RGB	
	04011104	Ultra-Thin 441 LED panel 35W,Single Blue	
	04011181	Ultra-Thin 531 LED panel 50W,Warm white	
	04011179	Ultra-Thin 531 LED panel 50W,Cool white	
	04011180	Ultra-Thin 531 LED panel 50W,RGB	
	04011178	Ultra-Thin 531 LED panel 50W,Single Blue	
7	03011360	M3*5 round head screw	2
8	02021085	Silica gel ring	1
9	01050105	Bottom cover	1
10	03011361	M4*10 round head self-tapping screw	5
11	02010285	NBR ring	2
12	04013004	2 *1 .5mm ² *2 .5m (D8)Cable	1
13	03012125	M4*10 flat head self-tapping screw	2
14	01050100	Cable Clip	3
15	89041604	Wate Joint Fittings for Cable	1
16	01171101	EL-H200 Lighits niche	1
17	01171106	Joint for Wine & Pipe	1



EL-H200

UNDERWATER LIGHT OPERATING MANUAL EL-H200

Keep this manual for future reference

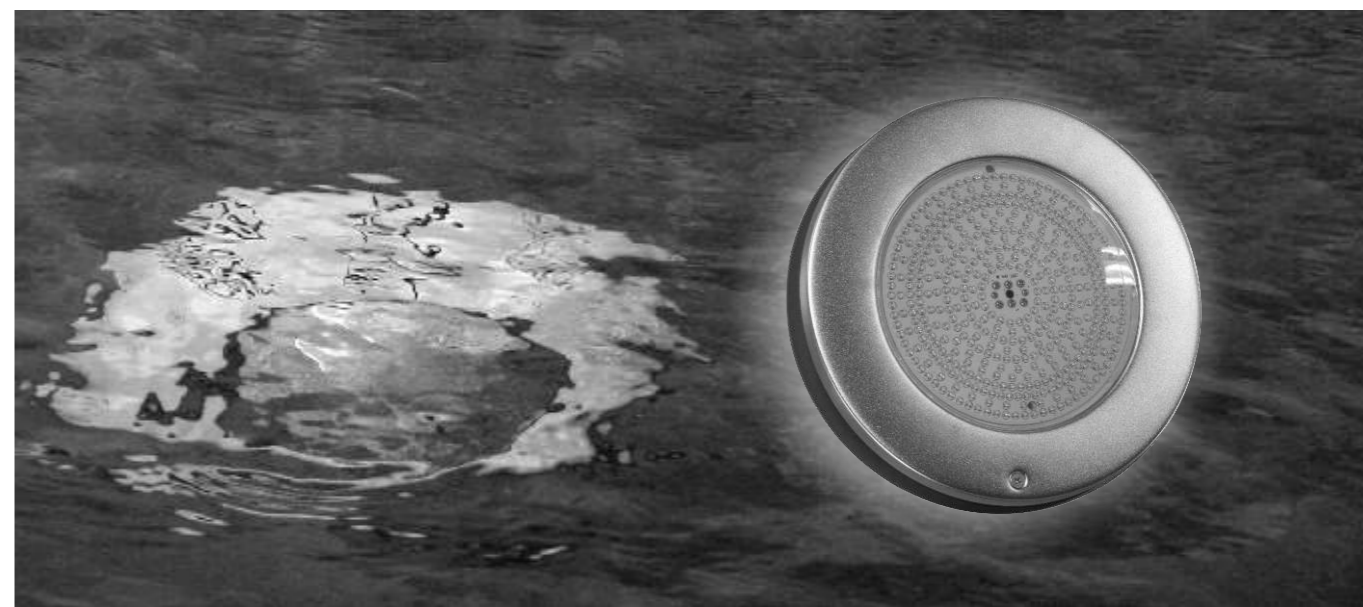

▲ SAFETY WARNINGS

- Only qualified electrician is allowed to carry out the installation of this product.
- Avoid direct contact with electrical power.
- Respect all regulations in effect for preventing accidents.
- All units are required to be disconnected from the main electricity before any operation of maintenance.
- Never handle with wet hands and feet.
- This unit is design for use only when fully submerged in fresh water, connecting with a safety transformer
- Never operate this Underwater Light for more than 1 minute unless it is totally submerged in water.
- Be sure power is off before installing or removing LED plate. Allow LED plate to cool before replacing.
- This product should be installed according to your local electrical installation ordinances and regulations.
- Maximum Water Temperature Range for light operation 0 - 30°C

A) Electrical Specification : 1) Voltage : AC12V 2) Frequency : 50/60Hz 3) Power : 20W / 35W / 50W.

B) Colour Options(For RGB version only) :

1	White	2	Green
3	Blue	4	Green+Blue
5	Red+Green	6	Red+Blue
7	Mode A: Blue+ Gradual Red	8	Mode B: Green+Gradual Red
9	Mode C: Blue+Gradual Green	10	Mode D: Blue+Gradual Red
11	Mode E: RGB Colour Sequence: Red>Green>Blue	12	Auto Colour Change
13	Mode F: Four Colour Sequence: Red>Green>Blue>Purple	14	Rapid Auto Colour Change

I. Installing light fixture during new pool construction.

A) The electrician must complete preparatory steps before light fixture is installed; see Figure 1.

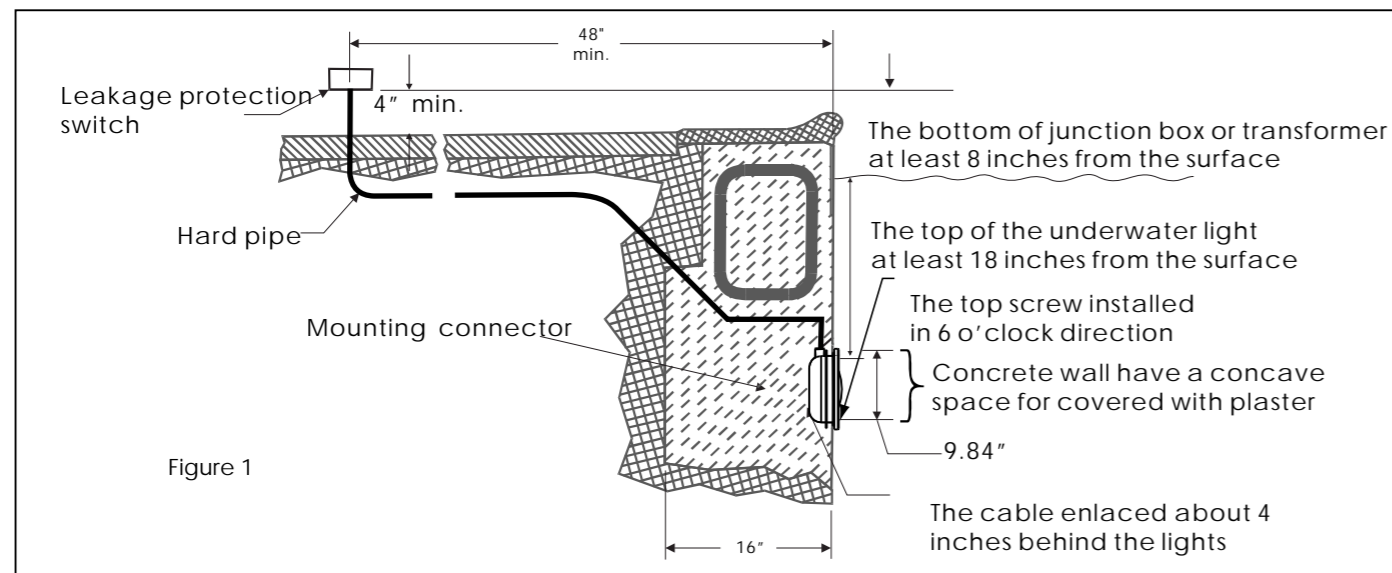

1) Ensure that the pool meets the requirements of the current National Electrical Code and all local codes and ordinances. A licensed or certified electrician must install the electrical system to meet or exceed those requirements before the underwater light is installed. Some of the requirements of the National Electrical Code which the Pool's electrical system must meet are as follows.

- The lighting circuit must have a Ground Fault Circuit Interrupter (GFCI), and must have an appropriately rated circuit breaker.
- The Junction Box (or, for 12 volt models, the low voltage transformer) must be located at least 20CM above water level, at least 10CM above ground level, and at least 120CM from the edge of the pool; see Figure 1.
- The light fixture and all metal items within 152CM of the pool must be properly electrically bonded.
- The wet niche must be properly installed so that the top edge of the underwater light's lens is at least 45.5 below the surface of the water in the pool; see Figure 1.
- The wet niche must be properly electrically bonded and grounded via the No.8 AWG ground connector located at the rear of the niche; see Figure 1.

NOTE: The pool or spa electrical system can be verified with a pool and Spa Electrical Qualification Test kit. The electrical system inspection using this kit must be performed by trained and certified personnel.

- To be certain that pool's electrical system meets all applicable requirements, the electrician should also consult the local building department.
- Terminal blocks must meet the IEC60988-2-1 standard having the rated connecting capacity of 4,0mm² use of screw-type terminal at least 25A rated current, mounted on junction boxes inside. See Figure 2-1

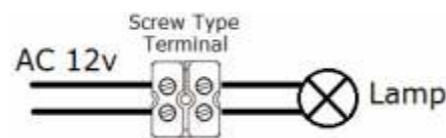

Figure 2-1

B) Steps to perform after the electrical system requirements are met.

- Feed cord through conduit to Junction Box, leaving at least 120CM of cord at the light fixture to coil

around the light; see Figure 1. This 120CM of cord around the light allows the light to be serviced after the pool is filled with water.

- Cut the cord at the Junction BOX, leaving at least 15CM of cord to make connections.
- Strip 15CM of the outer cord jacket to expose the three insulated wires. Be careful not to damage the insulation on the three (3) inner wires.
- Connect all three (3) wires to the corresponding circuit wires in the Junction Box, and secure the Junction Box cover in place.
- Replace the light assembly into niche and tighten special pilot screw.
- Fill the pool until the underwater light is completely submerged in water before operating the light for more than 10 seconds. Turn on main switch or circuit breaker, as well as the switch which operates the underwater light itself, to check for proper operation.

II. Installation

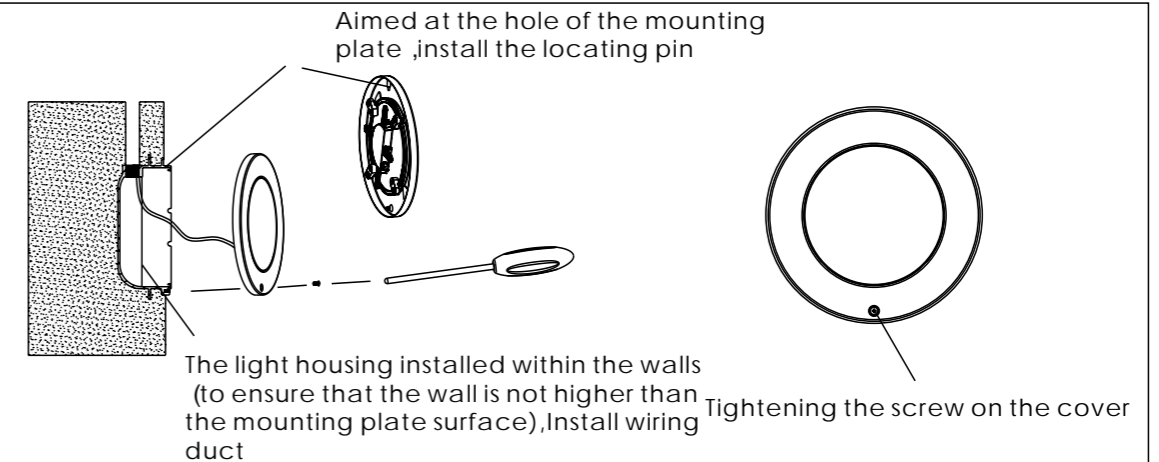

Figure 2

III. Maintenance of the Lights

- Do not leave the lights "on" above water for longer than 1 minute.
- Do not leave the lights directly under sunlight. Fill the pool with fresh water as soon as possible after the lights are installed.
- Before switching on the lights, check whether the lights are fully submerged underwater and the circuit boxes are running properly.
- This unit does not need any kind of maintenance. If it is not working properly, please contact EMAUX authorized dealer where you purchase the unit from.
- Warranty will be voided if the Emaux Underwater Light was dismantled by unauthorized personnel.

WARNING

Never operate this Underwater Light for more than 10 seconds unless it is totally submerged in water. Without total submersion, the light assembly will get extremely hot, which may result in serious injury to pool users, installers, or bystanders, or in damage to property.

Use only the special stainless steel pilot screw provided with Underwater Light. Failure to use the screw provided could create an electrical hazard which could result in death or serious injury to pool users, installers or others due to electrical shock.