

- C) To remove light assembly, remove the special pilot screw at top of face ring, remove light assembly from niche, and place assembly on deck.
- D) Disassemble light fixture and remove LED panel.
- E) Secure the face ring to the light fixture. Sealing screws must be tightened in the following manner to ensure a proper seal.
- F) Replace the light assembly into the niche and tighten the special pilot screw.

**WARNING**

Use only the special pilot screw provided with this underwater light. This screw mounts and electrically grounds the housing securely to the mounting ring and wet niche. Failure to use the screw provided could create an electrical hazard which could result in death or serious injury to pool users, installers or others due to electrical shock.

- G) Fill pool until the underwater light is completely submerged in water before operating the light for more than 60 seconds. Turn on main switch or circuit breaker, as well as the switch which specifically operates the underwater light, to check for proper operation.

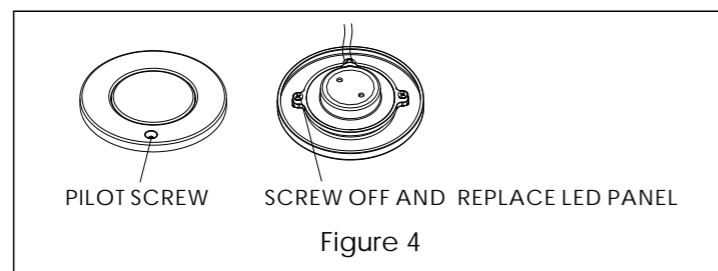

**MAINTENANCE OF THE LIGHTS**

- 1) Do not leave the lights "on" above water for longer than 1 minute.
- 2) Before switching on the lights, check whether the lights are fully submerged underwater and the circuit boxes are running properly.
- 3) This unit does not need any kind of maintenance. If it is not working properly, please contact EMAUX authorized dealer where you purchase the unit from.
- 4) Warranty will be voided if the Emaux Underwater Light was dismantled by unauthorized personnel.

**REPLACEMENT PARTS**

Item	Part No .	Product Description	Qty
1	3011058	Ø 33 /16x9 /8 "Pilot Screw	1
2	440256151	Face Ring Assembly for EL -S100 Lights	1
3	440546196	Ultra -thin 99 LED panel 10W Warm White	1
	440546195	Ultra -thin 99 LED panel 10W Cool White	1
	440546197	Ultra -thin 99 LED panel 10W RGB	1
	440546198	Ultra -thin 99 LED panel 10W Single Blue	1
4	03011354	M4 *8 Round Head Screw	2
5	88047302	Stainless Steel Housing	1
6	88043502	Plastic Housing	1

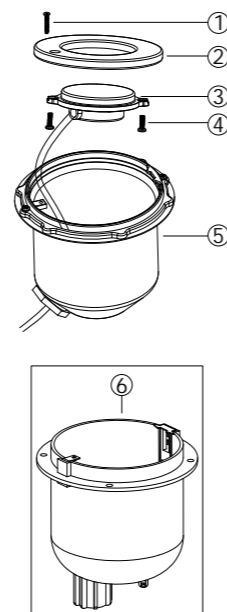

www.emauxgroup.com

# EL-S100

## UNDERWATER LIGHT OPERATING MANUAL

Model : EL-S100S / EL-S100P / EL-S100L  
Keep this manual for future reference

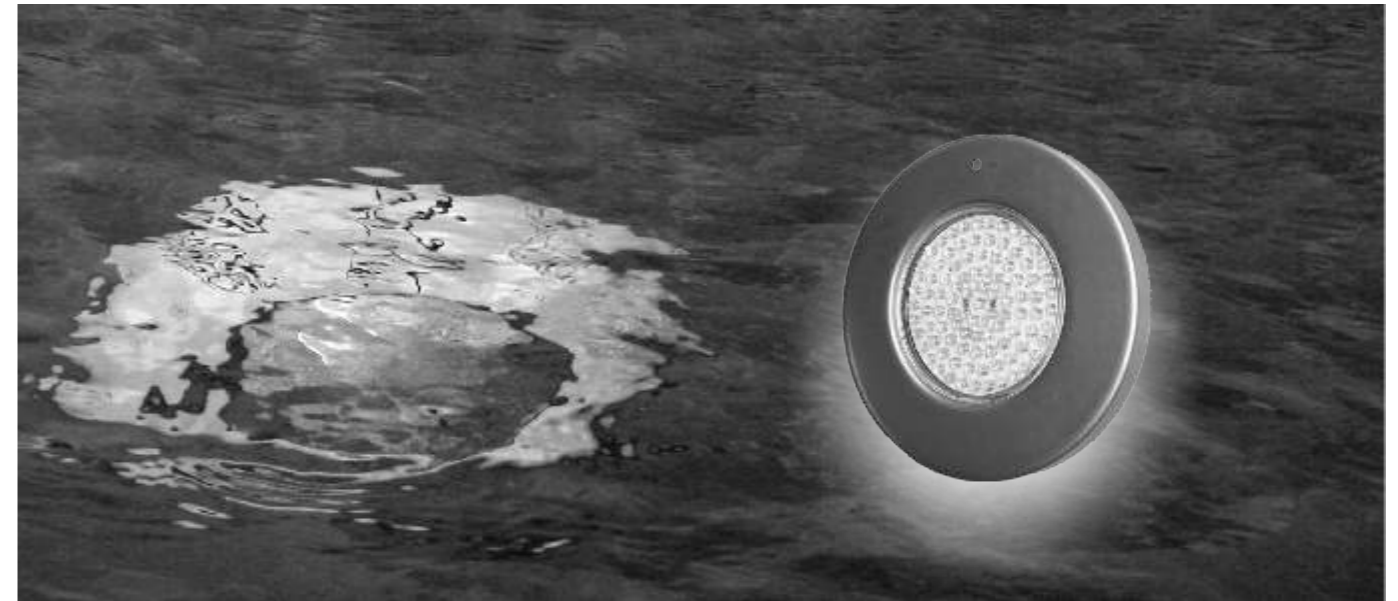

**SAFETY WARNINGS**

- Only suitably qualified installers is allowed to carry out the installation of this product.
- Avoid direct contact with electrical power.
- Respect all regulations in effect for preventing accidents.
- All units are required to be disconnected from the main electricity before any operation of maintenance.
- Never handle with wet hands and feet.
- This unit is design for use only when fully submerged in water, connecting with a safety transformer.
- Never operate this Underwater Light for more than 1 minute unless it is totally submerged in water.
- Be sure power is off before installing or removing LED plate. Allow LED plate to cool before replacing.
- This product should be installed according to your local electrical installation ordinances and regulations.
- Maximum Depth for Light installation at 1 meter.
- Maximum Water Temperature Range for light operation 0 - 30°C
- for type Z attachments  
The external flexible cable or cord of this luminaire cannot be replaced; if the cord is damaged, the luminaire shall be destroyed.

**SPECIFICATION**

- A) Electrical Specification : 1) Voltage : AC12V 2) Frequency : 50/60Hz 3) Power : 10W
- B) Colour change options(For RGB version only)

1	White	2	Green
3	Blue	4	Green+Blue
5	Red+Green	6	Red+Blue
7	Mode A: Blue+ Gradual Red	8	Mode B: Green+Gradual Red
9	Mode C: Blue+Gradual Green	10	Mode D: Blue+Gradual Red
11	Mode E: RGB Colour Sequence: Red>Green>Blue	12	Auto Colour Change
13	Mode F: Four Colour Sequence: Red>Green>Blue>Purple	14	Rapid Auto Colour Change

C) Control

- 1) When the light is connected to the transformer directly, the on/off switch controls the colour changes (Associating a light with a transformer and an on/off switch is recommended; If you want all the lights to change colour at the same time, install a master switch, Figure 1).
- 2) If applicable, when the light is connected to the transformer and the transformer to the optional control box, the control panel on the control box and its remote control controls the colour changes (See the Control Box Manual for details).

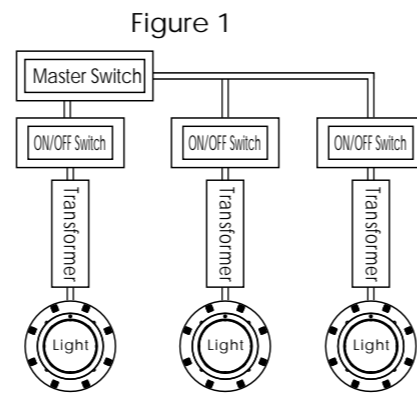

INSTALLATION NOTES

- 1) You should follow the procedures closely when installing the light.
- 2) It is recommended to install a light every 20m<sup>2</sup>, the approximate exposure area of each unit.
- 3) The lights should be installed in the direction that they will not shine directly into the house.
- 4) For training or competition pools, the lights must be installed on the sides in order to prevent swimmers from seeing any glare.
- 5) Nothing should be placed on the poolside directly above the lights for ease of future maintenance.
- 6) If the wires are connected inside the lights, you must seal the connections with leak-proof tapes or products with the same function.
- 7) The cables connecting the lights and the transformers must be at least 6mm<sup>2</sup> and the distance between them must not exceed 30m (Figure 2); otherwise the lights will not function properly.

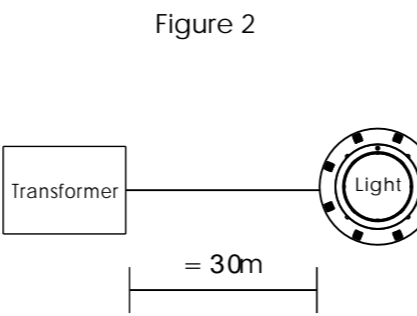

INSATALLATION OF THE UNDERWATER LIGHT

A) The electrician must complete preparatory steps before light fixture is installed; see Figure 1.

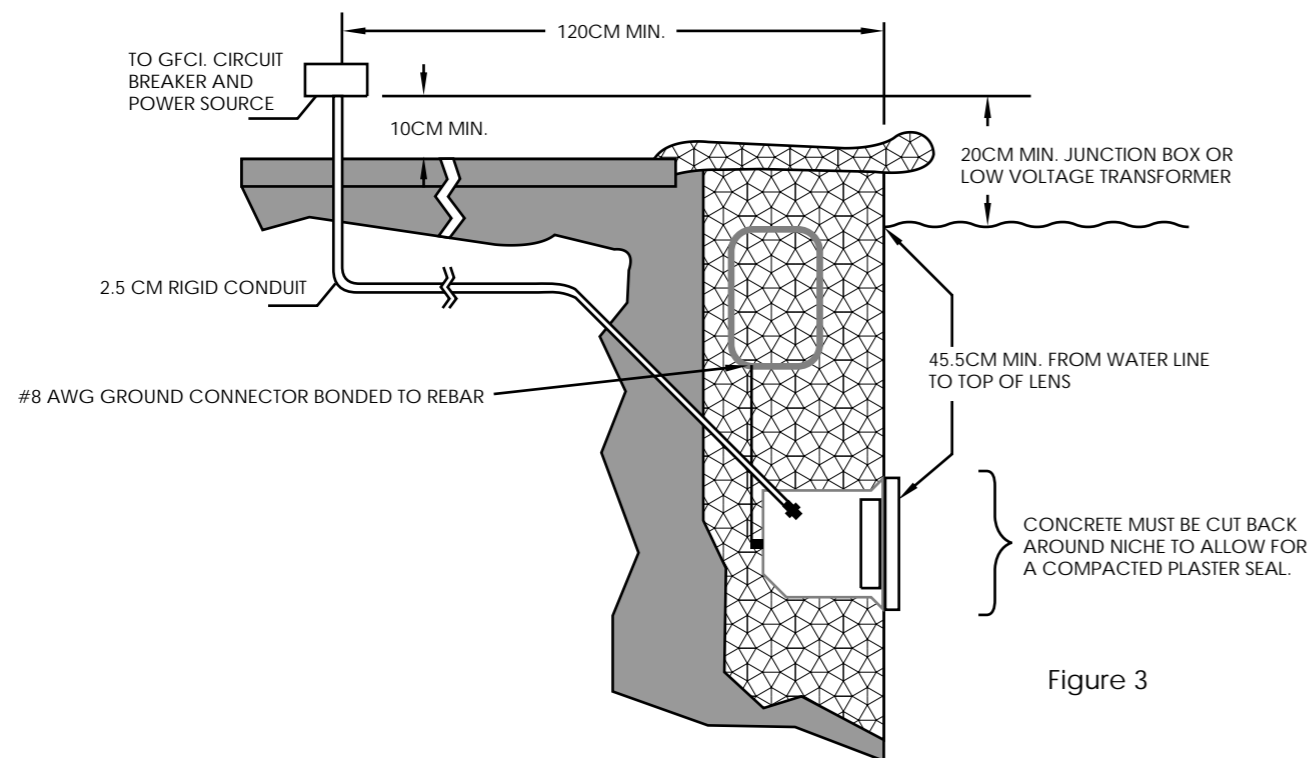

1) Ensure that the pool meets the requirements of the current National Electrical Code and all local codes and ordinances. A licensed or certified electrician must install the electrical system to meet or exceed those requirements before the underwater light is installed. Some of the requirements of the National Electrical Code which the Pool's electrical system must meet are as follows.

- a) The lighting circuit must have a Ground Fault Circuit Interrupter (GFCI), and must have an appropriately rated circuit breaker
- b) The Junction Box (or, for 12 volt models, the low voltage transformer) must be located at least 20CM above water level, at least 10CM above ground level, and at least 120CM from the edge of the pool; see Figure 3.
- c) The light fixture and all metal items within 152CM of the pool must be properly electrically bonded.
- d) The wet niche must be properly installed so that the top edge of the underwater light's lens is at least 45.5 below the surface of the water in the pool; see Figure 3.
- e) The wet niche must be properly electrically bonded and grounded via the No.8 AWG ground connector located at the rear of the niche; see Figure 3.

NOTE: The pool or spa electrical system can be verified with a pool and Spa Electrical Qualification Test kit. The electrical system inspection using this kit must be performed by trained and certified personnel.

2) To be certain that pool's electrical system meets all applicable requirements, the electrician should also consult the local building department.

B) Steps to perform after the electrical system requirements are met.

- 1) Feed cord through conduit to Junction Box, leaving at least 120CM of cord at the light fixture to coil around the light; see Figure 1. This 120CM of cord around the light allows the light to be serviced after the pool is filled with water.
- 2) Cut the cord at the Junction BOX, leaving at least 15CM of cord to make connections.
- 3) Strip 15CM of the outer cord jacket to expose the three insulated wires. Be careful not to damage the insulation on the three (3) inner wires.
- 4) Connect all three (3) wires to the corresponding circuit wires in the Junction Box, and secure the Junction Box cover in place.

WARNING

Never operate this Underwater Light for more than 60 seconds unless it is totally submerged in water. Without total submersion, the light assembly will get extremely hot, which may result in serious injury to pool users, installers, or bystanders, or in damage to property.

5) Replace the light assembly into niche and tighten special pilot screw.

WARNING

Use only the special stainless steel pilot screw provided with Underwater Light. Failure to use the screw provided could create an electrical hazard which could result in death or serious injury to pool users, installers or others due to electrical shock.

6) Fill the pool until the underwater light is completely submerged in water before operating the light for more than 60 seconds. Turn on main switch or circuit breaker, as well as the switch which operates the underwater light itself, to check for proper operation.

REPLACING A LED PANEL ONLY

DANGER

Always disconnect power to the pool light at the circuit breaker before servicing the light. Failure to do so could result in death or serious injury to installer, servicemen, pool users, or others due to electrical shock.

A) Turn off main electrical switch or circuit breaker, as well as the switch which operates the underwater light itself.

B) You will need the following items :  
A LED panel, refer to Table 1.

Replace a color panel of being needs. Failure to replace lamp with the same type of lamp will damage the light assembly and may cause an electrical hazard resulting in death or serious injury to pool users, installers, or others due to electrical shock, and may also cause damage to property.