

UL-H100 & UL-H200 Series Underwater Light User Manual

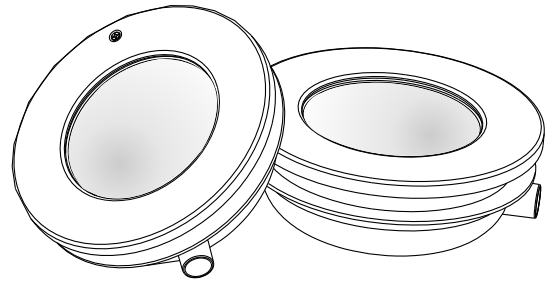

PLEASE READ THE FOLLOWING CAREFULLY AND
KEEP THIS USER MANUAL SAVE FOR FUTURE REFERENCE

DANGER !

RISK OF ELECTRICAL SHOCK OR ELECTROCUTION

This underwater light fixture must be installed by a licensed or certified electrician or a qualified serviceman in accordance to the requirements of your government standard or local authorities. Improper installation will create electric hazards which could result in serious injury, death as well as damage to the property. Before servicing the light, disconnect the power supply from the circuit breaker. Failure to do so could result in serious injury, death and or damage to the property.

⚠ WARNING ⚠

Preparatory steps which must be completed by the electrician before light is installed, see Figure 1.

- 1) Ensure that the electrical system and its wiring for the pool conform to the requirements of your government or your local authorities. The installation of the Underwater Light should only be performed by a licensed electrician.
 - a) The junction box, or the low voltage transformer for 12 volt Underwater Light model is to be located at least 120CM from the edge of the pool, see Figure 1.
 - b) The mounting bracket must be properly installed so that the top edge of the Underwater Light lens is at least 45CM below the surface of the water in the pool, see Figure 1.
- 2) The center of the mounting hub will line with the top of light lens. See Figure 2.
- 3) If pool surface is to be plastered, you must allow proper concrete cutback for plaster thickness.
- 4) Wrap a length of the cord up to a maximum of 240CM long on the back of the light assembly. Wind a minimum of three (3) wraps of cord so that the last wrap stops at the top of the light. This extra cord allows you to bring the light out of the pool for revamping and servicing.
- 5) The light fixture and all metal parts that are within 240CM of the pool must be properly protected with non-ductile materials and that the connections must be waterproof.
- 6) Consult the local Government Building Department to be certain that the pool's electrical system meets all applicable requirements.

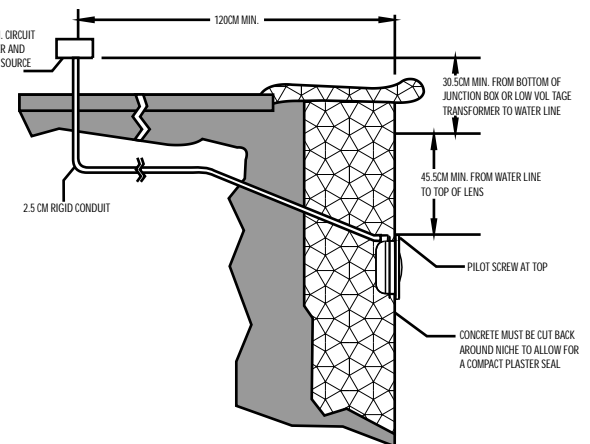

Figure 1.

INSTALLATION (for H100 & H200)

Perform the following steps after the electrical system requirements are met.

- 1) Locate position on a vertical wall where light is to be installed. The top of the light lens must be 45CM below normal water level, see Figure 1.
- 2) Connect conduit to midst of Mounting Spacer (left of Bracket), see Figure 3.
- 3) (For H100 vinyl pool only) If pool surface is to be plastered, you must allow proper concrete cutback for plaster thickness. Finish concrete surface must be flush with Mounting Spacer. CAUTION: Finish area surrounding Mounting Spacer MUST be flat and flush with the face of Mounting Spacer, this ensures a snug fit between light and wall, see Figure 2.
- 4) (For H100 vinyl pool only) Rotating Locking System ensures light is secured to bracket, see Figure 2.
- 5) After pool surface is finished, trim the Conduit.
- 6) Wrap a length of the cord up to a maximum of long on the back of the light assembly. This extra cord allows you to bring the light out of the pool for revamping and servicing.
- 7) Connect cord electrical wires at Junction box, through Conduit, be careful not to pull the 75mm-80mm of slack cord at the light through the conduit when connecting the wires.
- 8) Connect all wires to the corresponding circuit wires in the junction box and feed paraffin.
- 9) Secure the junction box cover in place.
- 10) Before operating the light for more than 10 seconds fill pool until the Underwater Light is completely submerged in water. To check for proper operation turn on main switch or circuit breaker as well as the switch that operates the Underwater Light itself.

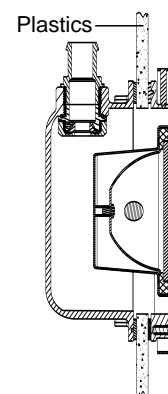

Figure 2.

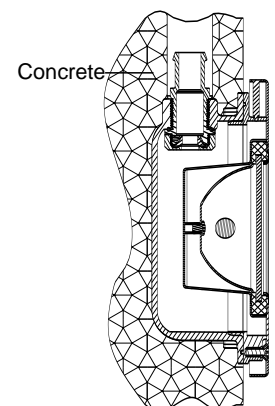
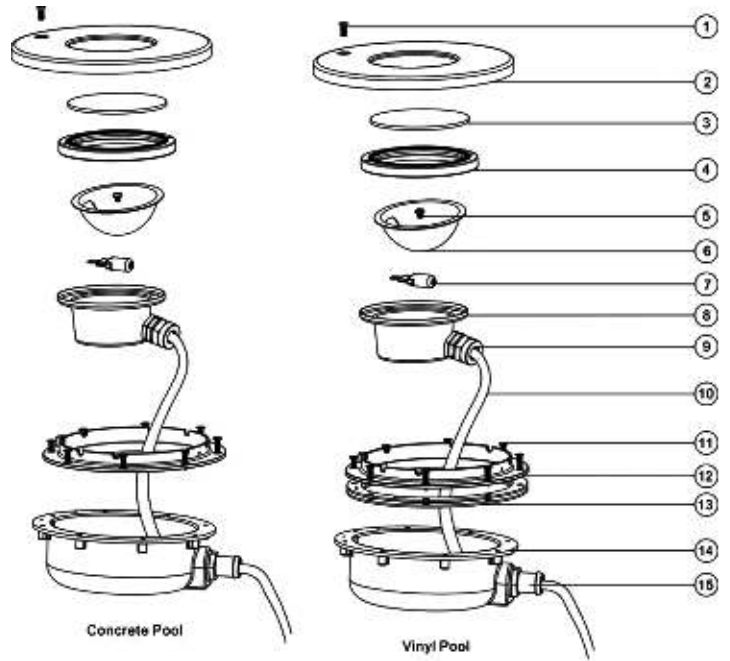

Figure 3.

Winterizing: Light should be left in place for winterization.

REPLACEMENT PARTS

UL-H100 Underwater Light Replacement Parts			
Key No.	Part No.	Description	Qty
1	03011123	M5*10 Screw for Lid	1
2	03018028	Lid For UL-H100 Lights	1
3	87012002	Glass Cover for UL-H100 Lights	1
4	02021014	Washer	1
5	03011046	M5*5 Round Head Screw	2
6	03031015	Reflector Cover for UL-H100 Lights	1
7	04011073	Bulb 12V/75W for ULH/ UL-NS	1
8	89041001	UL-H100 Lights for ULH/ UL-NS	1
9	89043701	Water Joint Fittings for cable	1
10	04013004	2.5M Cable	1
11	03011050	M4*30 Screw for Vinyl Pool	8
11	03011005	M4*12 Screw for Concrete Pool	8
12	01171095	Placement Plate with M5 Nut for Nuts	1
13	02051004	Washer for Vinyl Pool	2
14	01171099	UL-H100 Lights Niche	1
15	01171106	Joint for Wire & Pipe	1



UL-H200 Underwater Light Replacement Parts			
Key No.	Part No.	Description	Qty
1	03011123	M5*10 Screw for Lid	1
2	03018020	Lid for UL-H200 Lights	1
3	87012001	Glass Cover for UL-H200 Lights	1
4	02021012	Washer	1
5	03031016	Reflector Cover for UL-H200 Lights	1
6	04011073	Bulb 12V/75W for ULH/ UL-NS	2
7	03021040	M5 Nut	7
8	89041003	UL-H100 Lights Inner Base	1
9	89043701	Water joint fittings for cable	1
10	04013004	2.5M Cable	1
11	01171102	UL-H200 Lights niche	1
12	01171106	Joint for Wire & Pipe	1

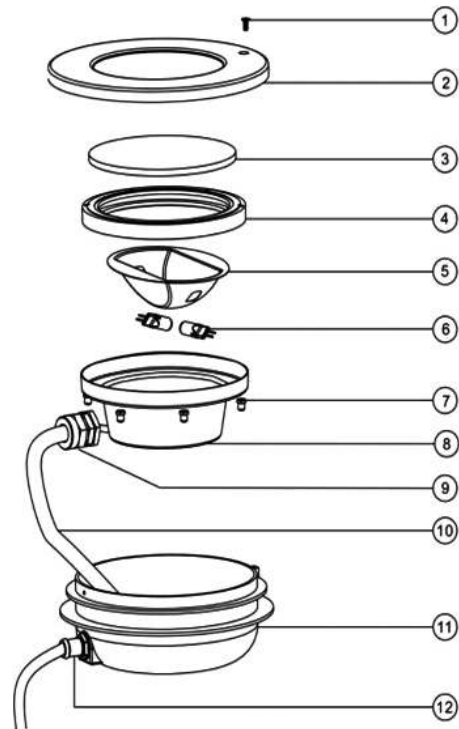

WARNING

 Never operate this Underwater Light for more than 10 seconds unless it is totally submerged in water. Without total submersion, the light assembly will get extremely hot, which may result in serious injury to pool users, installers, or bystanders, or damage to property.

 Be sure the power has been turned off before installing or removing lamp. Allow lamp to cool before relamping. This light fixture uses a Halogen Quartz lamp. Do Not touch lamp with bare hand as it may still be hot. Use a cloth or a non-ductile material to replace the lamp, this is also help eliminate finger prints from getting on lamp.