

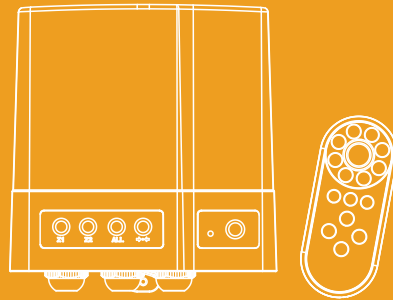

COLORTOUCH CONTROL BOX WITH REMOTE/WIFI CONTROL INSTALLATION AND OPERATION MANUAL



USER MANUAL

Model: COLOR TOUCH Series

TABLE OF CONTENT

PAGE	2 1. IMPORTANT SAFETY AND INSTALLATION INSTRUCTIONS
	2 2. PRODUCT INTRODUCTION
	3 3. SPECIFICATION
	4 4. INSTALLATION
		4.1 WIRING DIAGRAM
	5 5. CONTROL BOX PANEL OPERATION
	6 6. COLORTOUCH REMOTE HANDSET
		6.1 LEARNING PROCESS OF REMOTE
		6.2 THE REMOTE HANDSET
		6.3 BATTERY REPLACEMENT
	8 7. COLOR TOUCH WIFI CONNECTION
	8 8. MAINTENANCE AND TROUBLE SHOOTING
	9 9. REPLACEMENT PARTS
	10 10. TERMS OF THE WARRANTY

1. IMPORTANT SAFETY AND INSTALLATION INSTRUCTIONS

Please read the manual carefully before commencing installation. This manual contains important information about the correct installation and operation of E- Lumen X lights.

1. This ColorTouch control box must be installed by a licensed or certified electrician or a qualified serviceman in accordance to the requirements of your government standard or local authorities. Improper installation will create electric hazards which could result in serious injury, death as well as damage to the property.
2. Cut the power before service and maintenance!
3. For safe and proper installation, ensure that those parts supplied with the produce are used.
4. Never handle with wet hands and feet.
5. If the external flexible cable or cord of this ColorTouch control box is damaged, it shall be exclusively replaced by the manufacturer or his service agent or a similar qualified person in order to avoid a hazard.
6. Preferably installed in the place sheltered from rain or sunlight, ensure the longevity of these ColorTouch control box.

2. PRODUCT INTRODUCTION

Color Touch Control box incorporate with its exclusive wireless touch remote handset, provide easy pickup of preference color directly. But also have three level brightness dimming level for E-Lumen X light. The remote handset can be set to support other Emaux lights, such as E-lumen.

The control box local Z1, Z2, All and Reset keys can control all Emaux light color change in sequential way.

There are two light wiring zone with maximum power rating 2 x 300VA which is large enough to cover for large area swimming pool and SPA area.

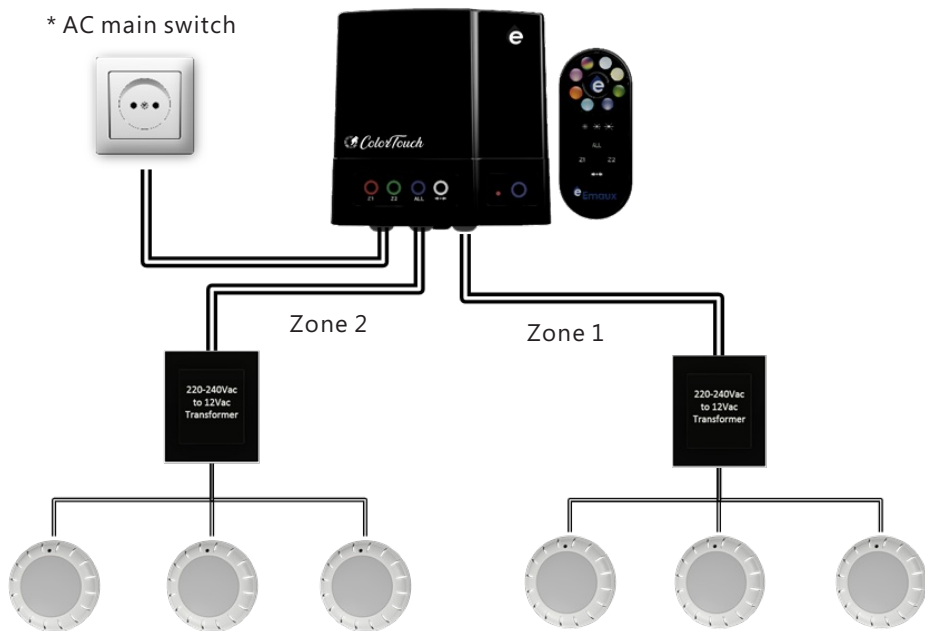

3. SPECIFICATION

Work Temperature	0-40°C
Input Voltage	AC110-220V, 50/60Hz
Output Voltage	2*AC110-220V, 50/60Hz
Maximum Power Rating	2*300VA
Radio Frequency	433MHz
Radio Distance At Sight(Empty area)	50m
Remote Battery	Cr2032

CONTROL BOX DISPLAY AND FUNCTION KEYS



Remote Handset

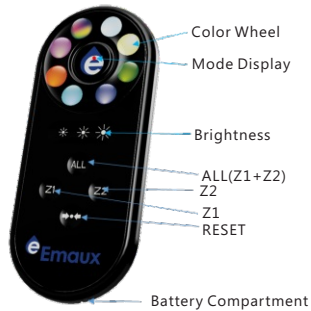

4. INSTALLATION

1. Remove the mounting bracket from the control box, position the mounting bracket to the desired fitting place and mark on the wall with the location of the drilled holes.
2. Then drill 4 holes of $\varnothing 8\text{mm}$ on the marked position and insert a plastic fitting, Secure the mounting bracket by fastening 4 screws of M5x35 to the plastic fittings as figure.
3. The ColorTouch control box is hanged on the hook of mounting bracket, and secure the bottom screw.



4.1 WIRING DIAGRAM

1. Unscrew the screws from the bottom and take out the housing carefully.
2. Remove the waterproof connector nut and put the transformer 110-220Vac cable through it.
3. Mount the two wires on the connector as figure.



WARNING:

The terminal voltage is 110-220Vac and never mount the light on it directly! When input terminal voltage is 220Vac, must connect to 220Vac transformer, not 110Vac transformer.

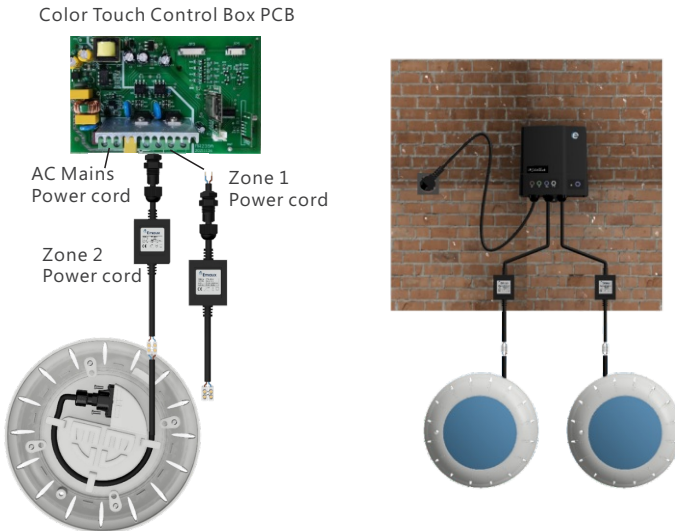

5. CONTROL BOX PANEL OPERATION

1. switch on the main power switch to turn on the power, the standby button led will light up.
2. press the standby button, ands the system is entered to operation mode.
3. Z1 Button - long press (3 second) to switch ON / OFF Z1 power. And short press (1 second) to change color for all the pool lights, connected to the Z1 outlet, the Z1 Button LED is flashing.
4. Z2 Button - long press (3 second) to switch ON / OFF Z2 power. And short press (1 second) to change color for all the pool lights, connected to the Z2 outlet, the Z2 Button LED is flashing.
5. ALL Button - Long or short press to change color for all the pool lights, connected to the Z1 and Z2 outlet, the ALL Button LED is flashing.

6. RESET Button - Press the button to reset all the pool lights connected to Z1 & Z1 to cool white color.



6. COLORTOUCH REMOTE HANDSET

Each Each control box is associated with a ColorTouch remote handset. It needs to pair the control box and handset by learning process as below:

6.1 LEARNING PROCESS OF REMOTE

Switch off main power button of the box before pressing the learn key of the box. Then switch on main power button and pressing the Learn Key locate under the box, the Learn key display is flashing in white color.

While keep pressing Learn Key of the box, pressing any key on the ColorTouch remote. When success link, the mode display on the remote (Emaux Water drop 'e') will be in red color and Learn Key display in the box is out .

If there is one remote for multiple control box, repeat the learning process to each control box.

6.2 THE REMOTE HANDSET

There are two operation mode to support Colortouch mode and basic tradition mode for lighting control.

6.2.1 COLORTOUCH MODE

It is the default control mode after learning.

1. The mode display LED under at the center of color wheel will be flashed in red color and ready to touch.
2. The ColorTouch remote choose direct color pick up just by touch the color area.
3. The rainbow color key is a toggle key for multiple modes of auto color change.
4. There are three level of brightness for light brightness adjustment by touch the desired brightness button.
5. Z1, Z2 and ALL are ON/OFF switch to ON/OFF Zone 1, Zone 2 and both Zones. The Reset key will turn Z1 and Z2 lights back to Cool White. It will take three seconds to the light up after switch off.
6. Touch any key and wait for a while for light response.



WARNING:

Put the finger on the top of button and touch it gently, then remote from it. Keep touching the same button will interrupt the handset operation.

6.2.2 BASIC MODE

1. The color wheel buttons and brightness function will be disabled.
2. Touch Z1, Z2 and all button will change the Zone 1, Zone 2 or Both Zones color one by one.
3. Reset button will turn all the light color to light's default first color for RGB color light. (E-Lumen mode)



6.3 BATTERY REPLACEMENT

Reverse the remote and open the battery compartment by pushing the right hand side lock inward. The remote use CR2032 battery that life time is around six months.



WARNING:

The Color Touch Control Box main power switch must be switched off and wait for three minutes and then switch on again.



WARNING:

The ColorTouch remote handset is designed with auto sleep mode to save battery power when it is idle for a while. It will wake up by touch any button and do the operation.

Switch to 50Hz/60Hz, wait 30s to open control box. If not, wrong color mode.



7. COLOR TOUCH WIFI CONNECTION

The latest Color Touch control box armed with WIFI access function from your home router. Therefore, you can control the E-lumen X lamp color, brightness, ON/OFF and etc same as remote handset.

1. The Android app can be download from Android marketplace.
2. Install the apps as usual and below icon will be shown on screen when installation finished.
3. Open your cell phone WIFI setting and connect to SSID "ColorTouch" with password 12345678.
4. Enter the APP, control the E-lumen X/ E-Lumen lamp color, brightness, ON/OFF and etc same as remote handset

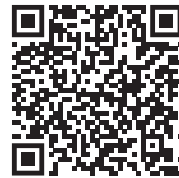

APP Download

8. MAINTENANCE AND TROUBLE SHOOTING

Do not leave the ColorTouch control box directly under sunlight.

Before switching on the control box, check the circuit boxes are running properly. Warranty will be voided if the Emaux ColorTouch control box was dismantled by unauthorized personnel.

Trouble	Possible Solution
Touch remote without response on Pool light	Replace battery CR2032. May enter water to damage remote.
The handset mode display correct but there is no response on Pool light	The remote handset is relearned by the learn key of control box.
The control box works normally, but pool light not response.	Check transformer. Replace pool light panel.
The ColorTouch box is not work.	Check main power button. Check connected locations of the cable. Check fuses at switch board. Contact qualified electrician to test.
Wrong color mode.	Switch to 50Hz/60Hz, wait 30s to open control box.

9. REPLACEMENT PARTS

Item No.	Part No.	Description	Qty
1	E111101	ColorTouch control box suite	1
2	E111110	ColorTouch electronic board 110-220V suite	1
3	510106781	Internal Plate	1
4	510116781	Bottom Plate	1
5	106176996	Power switch	1
6	E111102	Screw suite	1
7	04013004	Two-Core cable for output	1
7	105101306	Three-Core cable for input	2
8	106231416	Cable Gland	1
9	E111106	Switch for learn key suite	1
10	E111103	Mounting bracket suite	1
11	106697000	Remote (With Battery)	1

1

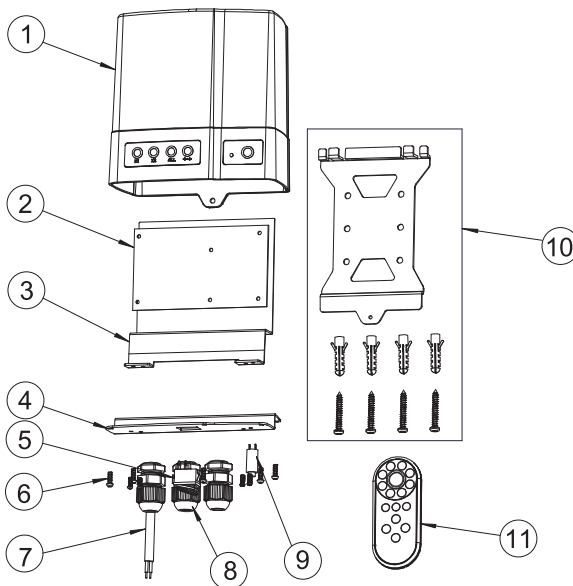

10. TERMS OF THE WARRANTY

As original purchaser of this equipment have purchased from Emaux Water Technology Co Ltd, through Authorized International Distributor or Dealer, warrants its products free from defects in materials and workmanship under normal use during warranty period. The warranty period begins on the day of purchase and extends only to the original purchaser. It is not transferable to anyone who subsequently purchases the product from you. It excludes all expendable parts.

During the warranty period, Emaux authorized reseller will repair or replace defective parts with new parts or, at the option of Emaux, serviceable used parts that are equivalent or superior to new parts in performance.

This Limited Warranty extends only to products purchased from Emaux authorized reseller. This Limited Warranty does not extend to any product that has been damaged or rendered defective

- (a) as a result of accident, misuse or abuse;
- (b) as a result of an act of God;
- (c) by operation outside the usage parameters stated herein;
- (d) by the use of parts not manufactured or sold by Emaux;
- (e) by modification of the product;
- (f) as a result of war or terrorist attack; or
- (g) as a result of service by anyone other than Emaux authorized reseller or authorized agent.

EXCEPT AS EXPRESSLY SET FORTH IN THIS WARRANTY, EMAUX MAKES NO OTHER WARRANTIES EXPRESSED OR IMPLIED, INCLUDING ANY IMPLIED WARRANTIES OR MERCHANTABILITY AND FITNESS FOR A PARTICULAR PURPOSE. EMAUX EXPRESSLY DISCLAIMS ALL WARRANTIES NOT STATED IN THIS LIMITED WARRANTY. ANY IMPLIED WARRANTIES THAT MAY BE IMPOSED BY LAW ARE LIMITED TO THE TERMS OF THIS EXPRESS LIMITED WARRANTY.

EMAUX WATER TECHNOLOGY CO., LTD

ADDRESS FLAT A-D, 20/F., KAI BO 22, 22 WING KIN ROAD,
KWAI CHUNG, HONG KONG
PHONE +852 2832 9880

 **YOUR PREMIER SUPPLIER**

www.emauxgroup.com