

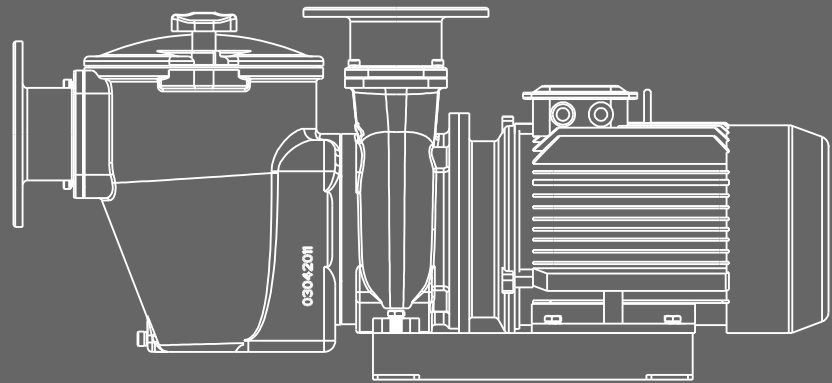

SE Series Owner's Manual Installation and Operation

Heavy duty cast iron pump



USER MANUAL



RoHS
COMPLIANT
2002/95/EC



SAA

Model: SE Series

TABLE OF CONTENT

PAGE	2 WARNINGS AND SAFETY INSTRUCTIONS GENERAL WARNING
3 SUCTION ENTRAPMENT HAZARD
4 1. SE SERIES CAST IRON PUMP OVERVIEW
4 2. PRODUCT INFORMATION
5 3. IMPORTANT SAFETY INSTRUCTIONS
6 4. INSTALLATION
	4.1 LIFTING THE PUMP
	4.2 LOCATION
	4.3 PIPING
	4.4 FLANGE INSTALLATION
	4.5 ELECTRICAL WIRING
	4.6 ELECTRICAL WIRING– 3 PHASE
10 5. START UP
11 6. ROUTINE MAINTENANCE
11 7. WINTERIZING
12 8. TROUBLE SHOOTING
13 9. REPLACEMENT PARTS
14 10. TERMS OF THE WARRANTY

WARNINGS AND SAFETY INSTRUCTIONS

GENERAL WARNING

This instruction contain general caution information for use in Pool and SPA pump installation application. Specified Pump model function should be refer to particular manual. Components such as the filtration system, pumps and heater must be positioned so as to prevent their being used as means of access to the pool by young children.



RISK OF ELECTRICAL SHOCK

This appliance should be installed by qualified electrical personnel in accordance with National Electrical Code and all applicable local codes and ordinances. Hazardous voltage can shock, burn, and cause death or serious property damage. DO NOT use an extension cord to connect unit to electric supply to reduce the risk of electric shock.

1. The pump should be permanently connected to an individual circuit breaker.
2. Pump must be connected to a residual current device (RCD) having a rated residual operating current not exceeding 30 mA or receptacle with ground fault circuit interrupt (GCFI).
3. Electrical grounding must be connected before connecting to electrical power. Failure to ground all electrical equipment can cause serious or fatal electrical shock hazard.
4. Bonding: Use at least #8 AWG (#6 AWG for Canada) a solid copper conductor, run a continuous wire from external bonding lug (if available) to the pressure wire connector provided on the electrical equipment and to all metal parts of swimming pool, spa, or hot tub, and metal piping (except gas piping), and conduit within 1.5 m (5 ft) of inside walls of swimming pool, spa, or hot tub.
5. Never open the inside of the drive motor enclosure. There is a capacitor bank that holds a mains supply voltage charge even when there is no power to the unit. The voltage should be referred to the individual pump operation voltage.
6. The pump is capable of high flow rates; use caution when installing and programming to limit pumps performance only.
7. Switch OFF pump power before servicing and disconnecting the main circuit to the pump.
8. Never change the filter control valve position while the pump is running.



COMPRESS AIR HAZARDOUS

This system enclosed pre-filter / filter and become pressurized. Pressurized air can cause the Lid to separate which can result in serious injury or death.

STAND CLEAR OF PUMP DURING START-UP

Pool and spa circulation systems operate under high pressure. When any part of the circulating system (i.e. lock ring, pump, filter, valves, etc.) is serviced, air can enter the system and become pressurized. Filter tank Lid and pre-filter cover must be properly secured to prevent violent separation. Place pre-filter / filter air relief valve in the open position and wait for all pressure in the system to be relieved before remove the lib to access the basket for cleaning.



HYPERTHERMIA

SPA water temperature excess 38°C (104°F) may be injurious to health. Measure water temperature before entering SPA.

Hyperthermia occurs when the internal temperature of the body reaches a level several degrees above the normal body temperature of 98.6 °F (37 °C). The symptoms of hyperthermia include drowsiness, lethargy, and an

increase in the internal temperature of the body.



SUCTION ENTRAPMENT HAZARD

This pump produces high levels of suction and creates a strong vacuum at the main drain at the bottom of your pool and spa. This suction is so strong that it can trap adults or children under water if they come in close proximity to a pool or spa drain or a loose or broken drain cover or grate.

The Virginia Graeme Baker (VGB) Pool and Spa Safety Act creates new requirements for owners and operators of commercial swimming Pools and spas.

Commercial pools or spas constructed on or after December 19, 2008, shall utilize:

1. A multiple main drain system without isolation capability with suction outlet covers that meet ASME/ANSI A112.19.8a Suction Fittings for Use in Swimming Pools, Wading Pools, Spas, and Hot Tubs and either:
 - 1.1 A safety vacuum release system (SVRS) meeting ASME/ANSI A112.19.17 Manufactured Safety Vacuum Release systems (SVRS)
For Residential and Commercial Swimming Pool, Spa, Hot Tub, and Wading Pool Suction Systems and/or ASTM F2387 Standard
Specification for Manufactured Safety Vacuum Release Systems (SVRS) for Swimming pools, Spas and Hot Tubs or
 - 1.2 A properly designed and tested suction-limiting vent system or
 - 1.3 An automatic pump shut-off system.

Commercial pools and spas constructed prior to December 19, 2008, with a single submerged suction outlet shall use a suction outlet cover that meets ASME/ANSI A112.19.8a and either:

1. A SVRS meeting ASME/ANSI A112.19.17 and/or ASTM F2387, or
2. A properly designed and tested suction-limiting vent system, or
3. An automatic pump shut-off system, or
4. Disabled submerged outlets, or
5. Suction outlets shall be reconfigured into return inlets.

There are five types of suction entrapment according to The Virginia Graeme Baker (VGB) Pool and Spa Safety Act

1. **Body Entrapment** a section of the torso becomes entrapped
2. **Limb Entrapment** an arm or leg is caught by or pulled into an open drainpipe
3. **Hair Entrapment** or entanglement hair is pulled into and/or wrapped around the grate of the drain cover
4. **Mechanical Entrapment** the bather's jewelry or clothing gets caught in the drain or the grate
5. **Evisceration** the victim's buttocks come into contact with the pool suction outlet and he or she is disemboweled



TO REDUCE ENTRAPMENT HAZARD RISK



WARNING:

Two function suction outlets per pump must be installed to prevent entrapment. The minimum separate of suction on the same plate must be at least point to point measurement 1 meter (3ft) apart. It is used to avoid "dual blockage" by bather.

If suction is found damage, broken, cracked, missing or not securely attached during regular checking, shunt down the pool and replace it immediately.

A vacuum release or vent system is recommended to install for suction entrapment release.

1. SE SERIES CAST IRON PUMP OVERVIEW

SE series pump is heavy duty pump in Cast Iron design for commercial pool and other fresh water treatment application.

It is constructed in full cast iron pump body with AISI-304 Stainless Steel pre-filter basket.

The impeller has an option to choice cast iron or AISI-304 Stainless Steel.

Large volume 5 liter Detachable pre-filter with basket design provide high flow rate application and flexible installation.

DIN PN10 compatible flange standard design to fit into different piping system environments.

It is 380Vac three phase electrical high power driving motor that is good for commercial swimming pool.



Cast Iron Impeller

AISI-304 Stainless Steel Impeller



2. PRODUCT INFORMATION

Model 50Hz	Input (kW)	Current (AMP)	Noise (dB)	Head(m)					
				8	10	12	14	16	18
				Flow Rate(m ³ /h)					
SE5.5	4.70	7	72	65	55	42.5	25	—	—
SE7.5	6.40	9	76	77.5	71	62.5	52.5	40	20
SE10	8.60	14	75	111.5	104	97	85	75	55
SE15	12.40	18	78	137.5	132.5	126.5	120	110	101

Code 380V/50Hz	Model	Connection Size	Horsepower	Output power (kW)	Voltage	Weight (kg)	A mm	B mm	C mm	D mm
88026816	SE5.5	3" / 90mm	5.5hp	4.0	380-420	95	860	415	DN80	DN80
88026811	SE7.5	3" / 90mm	7.5hp	5.5	380-420	100	860	415	DN80	DN80
88026812	SE10	4" / 110mm	10hp	7.5	380-420	118	915	445	DN100	DN100
88026813	SE15	4" / 110mm	15hp	11.0	380-420	130	945	445	DN100	DN100

DIMENSIONS(mm)

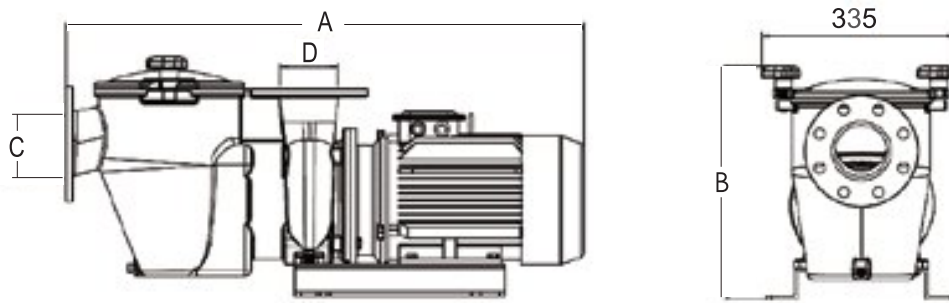

PERFORMANCE CURVE

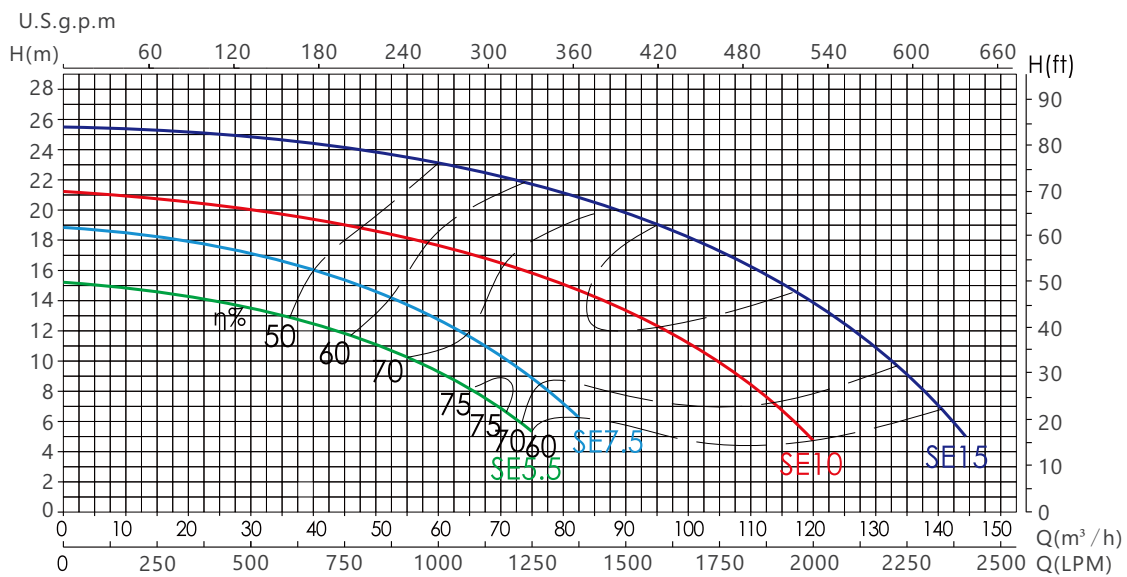

Remark: The performance curve above is for 50Hz models.

3. IMPORTANT SAFETY INSTRUCTIONS



WARNING:

The user guide you are holding includes essential information on the safety measures to be implemented for installation and start-up. Therefore, the installer as well as the user must read the instructions before beginning installation and start-up. Keep this manual for future reference.

1. A protective device is to be installed in the fixed wiring.
2. This appliance can be used by children aged from 8 years and above and persons with reduced physical, sensory or mental capabilities or lack of experience and knowledge if they have been given supervision or instruction concerning use of the appliance in a safe way and understand the hazards involved. Children shall not play with the appliance. Cleaning and user maintenance shall not be made by children without supervision.
3. The appliance shall be installed in accordance with national wiring regulations means for disconnection must be incorporated in the fixed wiring in accordance with the wiring rules. A disconnected incorporated in the fixed wiring is to be provided.
4. The pump is to be supplied through a residual current device (RCD) or Ground Fault Circuit Interrupt (GFCI) having a rated residual operation current not exceeding 30mA.

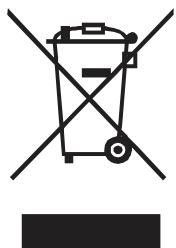
	Correct disposal of this product
	<p>This symbol on the product, or in its packaging, indicates that this product may not be treated as household waste. Instead, it should be taken to the appropriate waste collection point for the recycling of electrical and electronic equipment. By ensuring this product is disposed of correctly, you will help prevent potential negative consequences for the environment and human health, which could otherwise be caused by the inappropriate waste handling of this product. For more detailed information about the recycling of this product, please contact your local council, your household waste disposal service, or the shop where you purchased the product.</p>

4. INSTALLATION

4.1 LIFTING THE PUMP

The center of the pump locate at the middle of the pump. It is recommended to place the lifting strap under between Motor to Body and Body to pre-filter body and the other end to the eye bolt on the motor as below diagram.

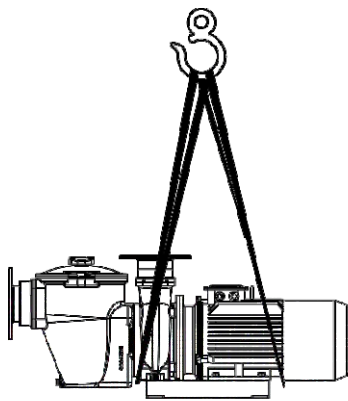

The EYE BOLT is only to use for motor lifting.

4.2 LOCATION

The pump should be located nearby as close as possible the pool or spa to reduce friction loss and improve efficiency. It is recommended at least 1.5 meter from pool water and 3 meters according to Canadian code.

1. It is suggested that the pump should be installed no more than 3m above ground level.
2. The pump should be placed and mounted on a solid foundation that will not vibrate. It must be bolted down to reduce noise from vibration. The area should be well drained to prevent flooding damage the motor.
3. Install the pump in a well thermal ventilated environment and to protect from excessive moisture.
4. Ensure there is enough clearance for pre-filter basket & Lid open and motor ventilation.
5. Fixed the pump on the ground by the 4 set M10x45 Hex head screw.

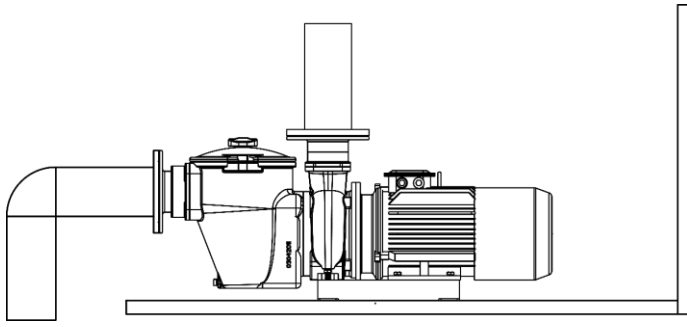

Foundation mounting



4.3 PIPING

Incorrect suction design is one of the main causes for problems appearing during the pump installations. The suction tube is one of the installation's main components, and it should meet the following conditions in order to avoid future problems.

1. It should be as short and straight as possible.
2. The Diameter of the tube should not be smaller than the diameter of the pumps inlet.
3. The suction tube should be fully airtight, if not the entry of air can cause de-priming of the pump.
4. The suction tube should have its own means of support and should not cause tensions or strains to the pump's flange.
5. Minimize the use of elbows, valves, narrowing or choking sections etc. which dangerously increase head losses and can cause air pockets as well as entry of air into the piping.
6. Each pump should have its own dedicated suction tube. If for unavoidable reasons it is necessary to connect two or more pumps to a single collector, the collector should have the same diameter from the first to the last outlet and should be sufficiently sized to supply the same flow rate to all pumps.

4.4 FLANGE INSTALLATION

1. The Pre-Filter inlet and pump body outlet is in DIN, PN10 standards flange type.
2. Place the 8 large bolts from the pipe flange side to the pump and place a 3.2mm thickness gasket in between.
3. Push the bolts to the pre-filter flange hole.
4. Keep the bolt straight and lightly snug each bolt with a wrench one by one until a squealing sound is heard to indicate that the bolts are being excessively tightened.

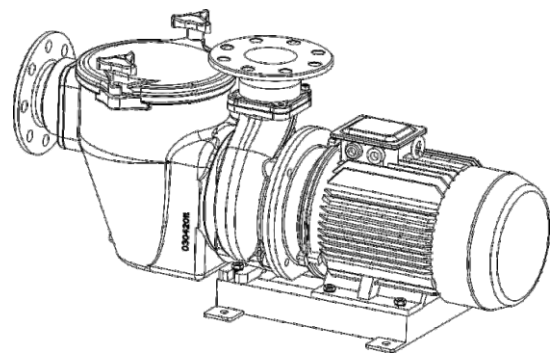
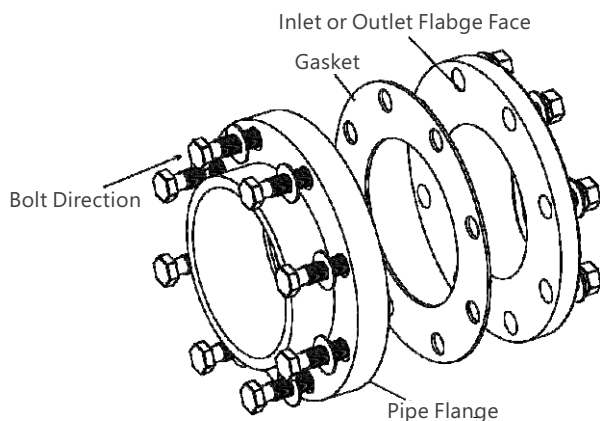

4.5 ELECTRICAL WIRING













This power pump demand licensed or certified electrician or qualified pool installer to ensure there is adequate protection between the pump motor and mains power supply according to individual countries safety code.

4.6 ELECTRICAL WIRING– 3 PHASE

APS PLASTIC pump operate at 3 phase power line to drive the motor. The latest cable color code is Brown for L1, Black for L2 , Grey for L3 , Blue for Neutral and Green & Yellow for Earth.

For old code it is Red for L1, Yellow for L2, Blue for L3 , Black for Neutral and Green & Yellow for Earth.

3 phase Cable New Wire Color Code		3 phase Cable Old Wire Color Code	
L/L1	 Brown	L/L1	 Red
L2	 Black	L2	 Yellow
L3	 Grey	L3	 Blue
N	 Blue	N	 Black
Earth	 Green & Yellow	Earth	 Green & Yellow

DOL starting is the simplest, cheapest and most common starting method. It actually gives the lowest temperature rise within the motor during startup of all the starting methods. But the drawback is starting current can be 3-8 time of full load current. Therefore, it is not recommend for pump power higher than 5.5KW in public low voltage mains 400V.

The typical common 3 phase pump Run / Stop starter is Direct-On-Lone Starter that include:

1. Motor Circuit Breaker is a short circuit magnetic protection devices.
2. Control unit for Run and Stop operation and status monitoring.
3. Protection relay is an overload thermal protection device.
4. Single phase MCB for secondary protection.



WARNING:

It is a typical wiring diagram It is a typical wiring diagram without ground wire for reference only. All electrical rating of individual device has to match with pump's current rating specification

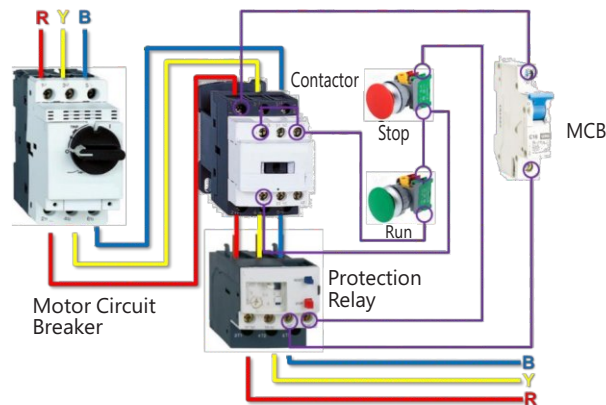

Direct-On-Line (DOL) Starter typical wiring.



WARNING:

Note: This high power pump demand licensed or certified electrician or qualified pool installer to ensure there is adequate protection between the pump motor and mains power supply according to individual countries safety code.

Open the terminal box on the top of the motor, there are six terminals and Ground. It can be connected in Delta or WYE / STAR connection. 380VAC 50 Hz + 10% and -6% electric power is three phase power source voltage range.

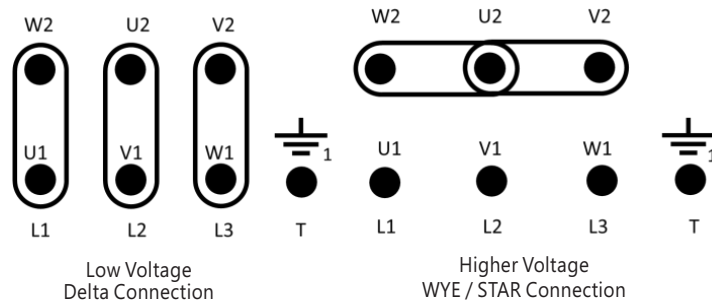

The factory connection is a Dealta connectiton



3 phase power 4 wires power line connection

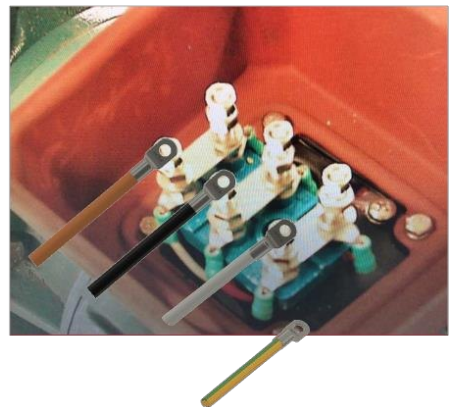

Terminal Box



Green & yellow Groudn wire location

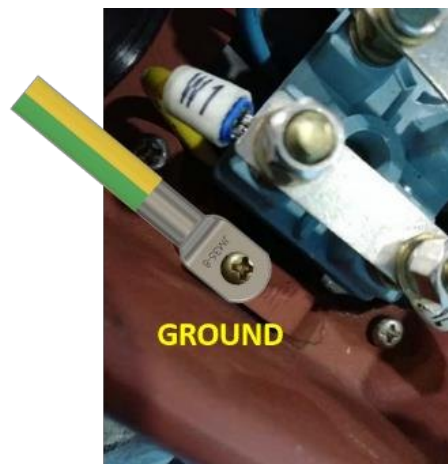

1. Every power lines have to be protected by circuit breaker for over load to isolated the motor from the mains power and provide protection to motor.
2. Three Phase starter switch or magnetic switch has to been applied to switch the pump on or off.
3. The motor run in counter clockwise when it is viewed from the front side of the motor. There is a rotation arrow on the pump body to show the right direction. Turn on the pump in one second and check the motor rotation direction is correct or not. The motor will rotate in Clock wise direction if any two cables are interchange. Fixed the cable location when rotation direction is wrong.
4. For insulation countries regulated by International Electrotechnical Commission (IEC) standards, the power lines must supply through a residual current device (RCD) having a rated tripping current not exceeding 30mA has to been installed.

5. START UP



WARNING:

1. Verify the pump shaft turn freely.
 2. Check the mains voltage, current and frequency are accordingly to the name plate.
 3. Never run pump dry! Running pump dry may cause damage to the mechanical seal causing leakage and flooding. Fill the pre-filter with water before starting motor.
 4. Before removing the pre-filter lid, STOP PUMP, CLOSE GATE VALVES in suction and discharge pipes.
5. Never tighten or loosen screw while the pump is in operation.
 6. The suction pipe and the suction inlet in the pool must be free from obstruction.

Before start-up, the alignment of the pump should be checked. The tubing should be inspected to ensure that they are properly fitted and tightened and that they do not exert pressure or tension on the pump's suction or discharge flange. The pump should never be operated.

1. Clear all piping of construction debris and verify that the piping has passed a proper pressure test.
2. Check the filter and other equipment for proper installation, verifying all clamps and connections are properly installed as per the manufacturer's instructions.
3. Open any shut off valves on the suction and discharge lines.
4. Open the filter pressure relief valve and release all pressure from the system.
5. If the pump is located below the water level of the pool, opening the pressure relief valve will fill the pump with water.
6. If the pump is located above the pool water level, remove the lid from the pre-filter and fill with water before starting the pump.
7. Check to see that the lid O-ring and seat areas are clean and lubricated. Debris in the sealing area can cause air to leak into the system and make it difficult to prime the pump.
8. Close/tighten the lid to make an airtight seal.
9. Turn on the pump.
10. If the pump does not prime and all instructions to this point have been followed, check for suction leaks and repeat steps (I) through (VIII).

6. ROUTINE MAINTENANCE

The Pre-Filter Basket of the pump should be visually inspected at least once a week. Remove the Lid and take out the basket, and clean debris from basket. Inspect the Lid O-ring; if damaged replace.

1. Turn off the pump at the breaker.
2. Close the inlet and discharge valves.
3. Discharge the water by drain on the pre-filter bottom,
4. Release the two star shape fasteners on the top of Lid slowly to release the pressurized air inside the pre-filter.
5. Remove the Lid to take out the basket.
6. Remove the debris and rinse out the basket.
7. Reinstall the Lid by placing the lid back onto the Pre-Filter body with Lid O-ring is properly placed around the entire sealing surface of the Pre-Filter body.
8. Open the inlet and discharge valves.
9. Turn the power "ON" at the circuit breaker
10. Open the manual air relief valve on top of the filter.
11. Stand clear of the filter. Start the pump.
12. Bleed air from the filter until a steady stream of water comes out. Close the manual air relief valve.

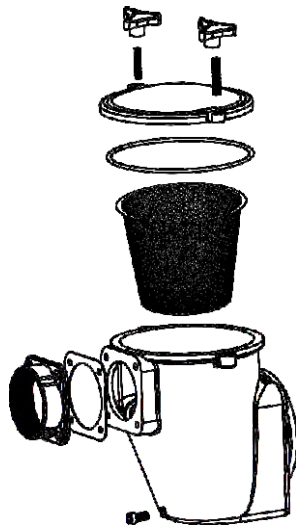

7. WINTERIZING

If the air temperature drops below 0°C (35°F), the water in the system can freeze and cause damage. Freezing damage is not warrantable.

To prevent freezing damage follow the procedures listed below:

1. Shut off electrical power for the pump at the house circuit breaker.
2. Drain the water out of the pump case by removing the two drain plugs from the case.
3. Store the plugs in the pump basket.
4. Cover the motor to protect it from severe rain, snow and ice.
5. If it is possible, store the pump in a dry location during this time.
6. Do not wrap the motor in plastic. It will cause condensation and rust on the inside of the motor.
7. Where possible, have a qualified service technician or electrician disconnect the electrical wiring at the switch or junction box and store the pump indoors.
8. When the pump is reactivated, ensure all seals and O-rings are in operational condition. If they are not, re-greasing or replacing may be necessary.

8. TROUBLE SHOOTING

Problem	Corrective Action
Pump Will Not Prime	<ol style="list-style-type: none"> 1. No water in Pre-filter Lid is not tight Damaged lid O-Ring 2. Water level below Skimmer 3. Pre-filter or Skimmer Basket clogged Closed Valve in Piping System 4. Air leak in Suction Line 5. Pump installed more than 10 ft.(3 m.) above Water Level or otherwise too high for Hydraulic Conditions of Pool Plumbing System 6. Pump Shaft rotating in wrong direction
Low Flow- High Filter Pressure	<ol style="list-style-type: none"> 1. Filter is dirty 2. Restriction in Filter Line
Low Flow- Low Filter Pressure	<ol style="list-style-type: none"> 1. Pre-filter or Skimmer Basket clogged 2. Clogged Impeller 3. Air leak in Suction Line Restriction in Suction Line
Motor Does Not Turn	<ol style="list-style-type: none"> 1. Power Switch is off 2. Circuit Breaker has tripped Thermal Protector has tripped Pump is in OFF mode of Timer 3. Motor Shaft is locked by bad Bearing Impeller is jammed
Motor Over Heating	<ol style="list-style-type: none"> 1. Electrical Supply Connections are incorrect Wiring to Pump is undersized 2. Inadequate Voltage supplied to Site Ventilation is inadequate for Motor 3. Voltage differential between legs of 3 Phase Circuit >5% 4. Pump Shaft rotating in wrong direction
High Pitch OR Growling Noise Coming from WET END of Pump	<ol style="list-style-type: none"> 1. Air Leak in Suction Line 2. A Valve, Elbow or Tee is located too close to the Suction Inlet of the Pump 3. Pump Shaft rotating in wrong direction

9. REPLACEMENT PARTS

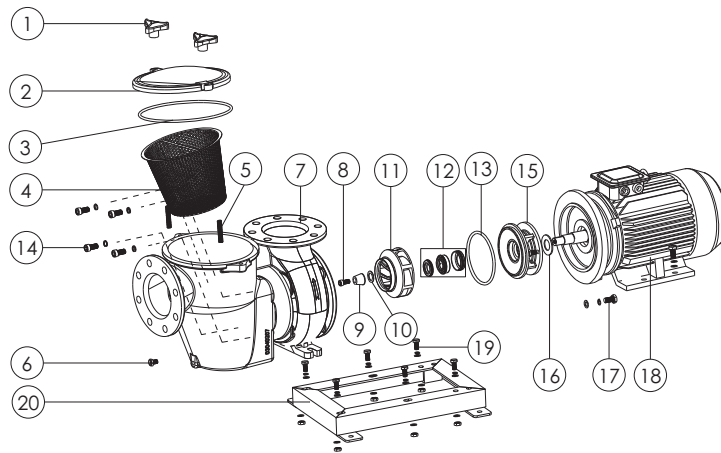

Key No.	Part No.	Description	QTY
1	03042009	Lid Fastener	2
2	03042010	Lid	1
3	02011148	Lid O-ring	1
4	03018039	Basket	1
5	03018163	Bolt	2
6	03011136	Drain Plug	1
7	03040206	Pump Body(SE5.5;SE7.5)	1
7	03040207	Pump Body(SE10;SE15)	1
8	03011086	M8×30 Bolt	1
9	03018101	Cone-shape washer for SE5.5;SE7.5 impeller	1
9	03018102	Cone-shape washer for SE10;SE15 impeller	1
10	87013025	Slinger for SE5.5;SE7.5 impeller	1
10	87013024	Slinger for SE10;SE15 impeller	1
11	03018096	Stainless Steel impeller SE5.5	1
11	03018097	Stainless Steel impeller SE7.5	1
11	03018098	Stainless Steel impeller SE10	1
11	03018099	Stainless Steel impeller SE15	1
11	03042015	Cast Iron impeller SE5.5	1
11	03042016	Cast Iron impeller SE7.5	1
11	03042017	Cast Iron impeller SE10	1
11	03042045	Cast Iron impeller SE15	1
12	04015020	Mechanical Seal(SE5.5;SE7.5)	1
12	04015021	Mechanical Seal(SE10;SE15)	1
13	02011164	O-ring for SE5.5;SE7.5 Flange	1
13	02011165	O-ring for SE10;SE15 Flange	1
14	03011140	screw for Flange	2

15	03042018	Flange (SE5.5;SE7.5)	1
15	03042007	Flange (SE10;SE15)	1
16	02011166	Motor Slinger (SE5.5;SE7.5)	1
16	02011167	Motor Slinger (SE10;SE15)	1
17	89025606	M12 Bolt	4
18	04021104	Motor SE5.5	1
18	04021105	Motor SE7.5	1
18	04021106	Motor SE10	1
18	04021107	Motor SE15	1
19	89025607	M12×35 Bolt	6
20	03042043	5.5-7.5HP Base	1
20	03042044	10-15HP Base	1

10. TERMS OF THE WARRANTY

As original purchaser of this equipment have purchased from Emaux Water Technology Co Ltd, through Authorized International Distributor or Dealer, warrants its products free from defects in materials and workmanship under normal use during warranty period. The warranty period begins on the day of purchase and extends only to the original purchaser. It is not transferable to anyone who subsequently purchases the product from you. It excludes all expendable parts.

During the warranty period, Emaux authorized reseller will repair or replace defective parts with new parts or, at the option of Emaux, serviceable used parts that are equivalent or superior to new parts in performance.

This Limited Warranty extends only to products purchased from Emaux authorized reseller. This Limited Warranty does not extend to any product that has been damaged or rendered defective (a) as a result of accident, misuse or abuse;

(b) as a result of an act of God;

(c) by operation outside the usage parameters stated herein;

(d) by the use of parts not manufactured or sold by Emaux;

(e) by modification of the product;

(f) as a result of war or terrorist attack; or

(g) as a result of service by anyone other than Emaux authorized reseller or authorized agent.

EXCEPT AS EXPRESSLY SET FORTH IN THIS WARRANTY, EMAUX MAKES NO OTHER WARRANTIES EXPRESSED OR IMPLIED, INCLUDING ANY IMPLIED WARRANTIES OR MERCHANTABILITY AND FITNESS FOR A PARTICULAR PURPOSE. EMAUX EXPRESSLY DISCLAIMS ALL WARRANTIES NOT STATED IN THIS LIMITED WARRANTY. ANY IMPLIED WARRANTIES THAT MAY BE IMPOSED BY LAW ARE LIMITED TO THE TERMS OF THIS EXPRESS LIMITED WARRANTY.

EMAUX WATER TECHNOLOGY CO., LTD

**ADDRESS FLAT A-D, 20/F., KAI BO 22, 22 WING KIN ROAD,
KWAI CHUNG, HONG KONG**

PHONE +852 2832 9880

 **STRIVE FOR CLEAR WATER**

www.emauxgroup.com